

## USE AND MAINTENANCE MANUAL

**MOWER TYPE "SRM" "PRM" "XRM"**

**MOWER TYPE "FM" "FMRD" "XFM"**

### PRM

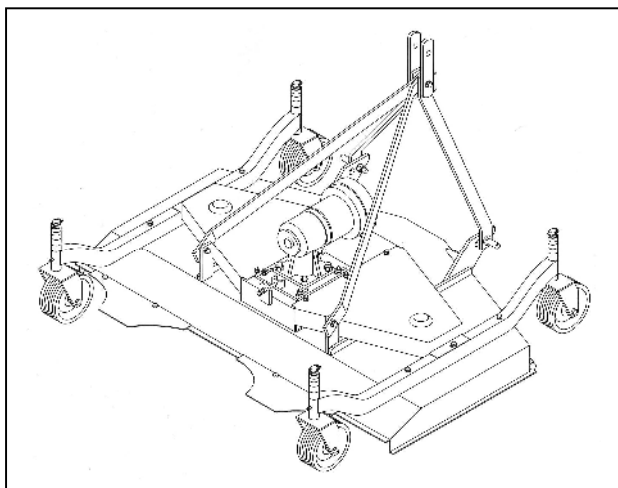

### SRM

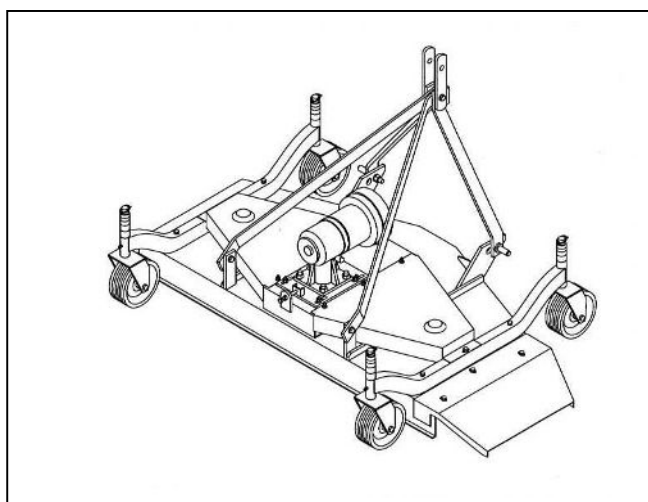

## PREFACE

### **This manual is an integral part of the machine.**

It must always accompany the machine and be kept within reach of the operator.  
The enclosures mentioned are an integral part of this manual.

### **The purpose of this manual.**

This manual gives information for the correct and safe use of the machine.  
The owner must read this manual carefully before work with the machine.

### **Responsibility of the owner**

The owner is responsible for accidents or damages caused to people or things due to negligence in following the instructions in this manual.

### **Assistance in using this manual**

Explanations: contact the dealer.

Request for additional copies of the manual: in case of loss or wear and tear, or in case one wants the manual in a different language, the customer should ask the dealer or manufacturer.

### **Pay attention to the warning signals**



**<Danger>**: indicates a situation that is potentially dangerous which, if not avoided, will cause death or serious damage.



**<Warning>**: indicates a situation that is potentially dangerous which, if not avoided, will cause death or serious damage.



**<Caution>**: indicates a situation that is potentially dangerous which, if not avoided, can cause minor to moderate damage or it indicates to be careful about an unsafe procedure.

**<Important>**: indicates instructions that must be followed precisely in order to avoid damage to the product, process or environment.

**<Note>**: indicates supplementary information.

## DESCRIPTION

### FUNCTION OF USE

The machine gives grass a professional cut. The grass is first raised, and then cut with precision and discharged rear or sideways along the width of discharge.

Improve the eventual preliminary cut.

The machine moves on the ground through four pivotal wheels, it's connected to the tractor through a three points hitch.

The machine takes motion through a PTO shaft connected to the tractor PTO.

The machine follows perfectly the line of the soil making a uniform cutting action of high quality.

### PERFORMANCES

The machine always has its four wheels on the ground.

The pivotal wheels of the machine, permit the best control both on forward gear and reverse gear, the wheels have dimensions so as not to damage the turf.

The height of the cut is adjustable from 1 to 4 inches through distance washers that can be inserted in the vertical pivotal axles.

### PERFORMANCES LIMITS

- Maximum forwarding speed: 3 m.p.h.
- Speeds greater than the maximum can compromise the condition of the machine, the quality of the work and the safety of the operator.
- Maximum power applicable to the gear box: from 15 to 46 KW  $\pm$  5% with 540 r.p.m.
- Superior power to which is indicated can damage irreparably the transmission gear box; especially during heavy works.

---

### STANDARD EQUIPMENT

- Standard PTO shaft- Rubber wheels – Front roll (XRM-XFM-PRM 215)
- Floating hitch (All USA versions) - page 22
- Centralized lubrication (XRM-XFM-PRM 215) - page 27

### VARIANTS & OPTIONS

- Pneumatic wheels  $\phi$  330 – Rubber wheels  $\phi$  310 - page 25
- Free wheel PTO shaft – Clutch PTO shaft – Bolt PTO shaft
- Transmission at 1000 or 2000 r.p.m./min - page 23-24
- Centralized lubrication (PRM-FMRD-SRM-FM) - page 27
- Kit mulching
- Front roll (PRM-FMRD-SRM-FM) - page 25
- Adjusting hitch (SRM) - page 26

## TECHNICAL SPECIFICATIONS

### CHARACTERISTICS PER MODEL

Model	Type	Power		PTO g/min	Working width		Cutting height		Blades N°	Blades speed g/min	3 points hitch Cat.	Weight	
		Hp	KW		cm	Inch	Cm	Inch				kg	Lbs
<b>SRM</b>	120	20	15	540	120	48	2,5÷10	1÷4	3	3250	1	167	370
	150	30	22	540	150	59	2,5÷10	1÷4	3	2630	1	183	405
	180	40	30	540	180	71	2,5÷10	1÷4	3	2250	1	226	500
	215	47	35	540	215	84	2,5÷10	1÷4	3	2125	1	262	580
<b>PRM</b>	120	20	15	540	120	48	2,5÷10	1÷4	3	3250	1	167	370
	135	25	19	540	135	54	2,5÷10	1÷4	3	3250	1	175	388
	150	30	22	540	150	59	2,5÷10	1÷4	3	2630	1	183	405
	180	40	30	540	180	71	2,5÷10	1÷4	3	2250	1	226	500
<b>XRM</b>	215	47	35	540	215	84	2,5÷10	1÷4	3	2125	1	262	580
	235	60	46	540	235	93	2,5÷10	1÷4	5	2630	1	310	686

Model	Type	Power		PTO g/min	Working width		Cutting height		Blades N°	Blades speed g/min	3 points hitch Cat.	Weight	
		Hp	KW		cm	Inch	Cm	Inch				kg	Lbs
<b>FM</b>	120	20	15	540	120	48	2,5÷10	1÷4	3	3250	1	167	370
	150	30	22	540	150	59	2,5÷10	1÷4	3	2630	1	183	405
	180	40	30	540	180	71	2,5÷10	1÷4	3	2250	1	226	500
	215	47	35	540	215	84	2,5÷10	1÷4	3	2125	1	262	580
<b>FMRD</b>	120	20	15	540	120	48	2,5÷10	1÷4	3	3250	1	167	370
	135	25	19	540	135	54	2,5÷10	1÷4	3	3250	1	175	388
	150	30	22	540	150	59	2,5÷10	1÷4	3	2630	1	183	405
	180	40	30	540	180	71	2,5÷10	1÷4	3	2250	1	226	500
<b>XFM</b>	215	47	35	540	215	84	2,5÷10	1÷4	3	2125	1	262	580
	235	60	46	540	235	93	2,5÷10	1÷4	5	2630	1	310	686

### MODEL IDENTIFICATION

- **SRM** : Rear mower with side discharge
- **PRM** : Rear mower with rear discharge
- **XRM** : Rear mower with rear discharge – five blades
- **FM** : Front mower with side discharge
- **FMRD** : Front mower with rear discharge
- **XFM** : Front mower with rear discharge – five blades

## SAFETY INFORMATION

### GENERAL REGULATIONS

- Only work in daylight.
- To prevent damage due to lurch of objects or parts of blades, before to start job be sure that any persons or animals should be in the radius of 50 meters from the machine.
- Wear long pants and heavy shoes.
- The protections are integral part of the machine: always work with the protections.
- Make sure that the 4 wheels of all components be adjusted to the same cutting height.
- Pay attention to the soil: make sure that are not stones, sticks, iron wires, etc...
- Pay attention using the machine on slopes: proceed to the maximum slope and never work in slanting direction.
- Before leaving the driver's seat, turn off the engine and disengage the transmission engine-shaft.
- Check immediately the machine if it touches foreign objects.
- Check immediately the machine if there are unusual strong vibrations.
- Change quickly defective parts.

### SAFETY RESTRICTIONS

Children and people who are not familiar with these instructions must not be permitted to use the machine. Local regulations can restrict the use of the machine in accordance to the age.

## SAFETY SIGNS ON THE MACHINE

In this section, the safety signs on the machine are reproduced and explained.



1

2

3

4

5

6

1. Read the operator manual.
2. Disconnect the tractor key before maintenance and repair operations.
3. Stay at safety distance from blades when machine is moving.
4. Danger of flying objects. Stay at safety distance.
5. Stay at safety distance from blades when machine is moving.
6. Stay at safety distance from blades when machine is moving.

**The safety signs on the machine must always be legible.**

In case of damage, the labels of the signs must be substituted.

In the case of the substitution of machine parts that have safety signs, the signs must be replaced.

**Supplying of new safety labels and the application procedure**

Contact your dealer to receive new safety labels with instructions for application.

## ASSEMBLING INSTRUCTIONS

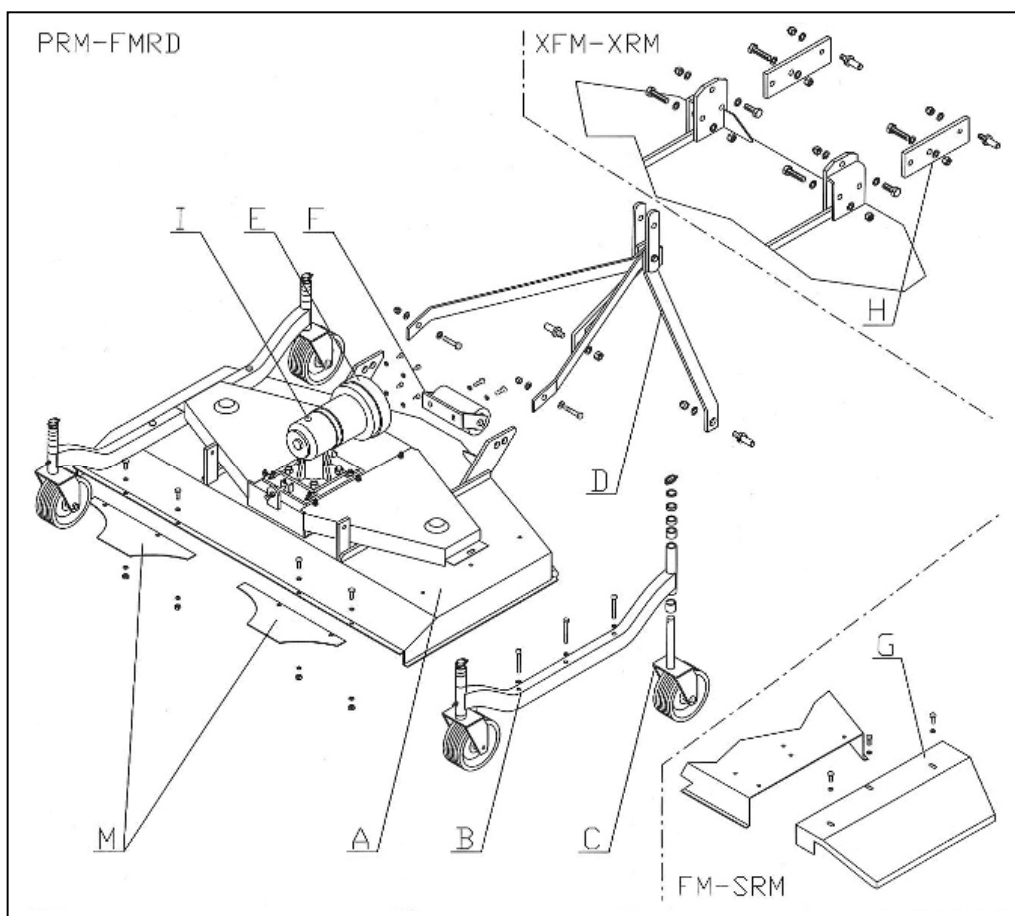

### 1. "PRM-FMRD" ASSEMBLING

- a) Assemble on frame "A" the two wheel brackets "B" and the four wheels "C".
- b) Assemble on frame "A" the hitch group "D" and, if bought, the front roll "F".
- c) Assemble on gear box the safety protection "E" and through plug "I" fill oil in foreseen type and quantity (see page 12).
- d) Assemble the two protections "M".

### 2. "SRM-FM" ASSEMBLING

- e) Assemble on frame "A" the two wheel brackets "B" and the four wheels "C".
- f) Assemble on frame "A" the hitch group "D", the discharge carter "G" and, if bought, the front roll "F".
- g) Assemble on gear box the safety protection "E" and through plug "I" fill oil in foreseen type and quantity (see page 12).

### 3. "XRM-XFM" ASSEMBLING

- h) Assemble on frame "A" the two wheel brackets "B" and the four wheels "C".
- i) Assemble on frame "A" the hitch group "D", the extensions "H" and the front roll "F".
- j) Assemble on gear box the safety protection "E" and through plug "I" fill oil in foreseen type and quantity (see page 12).
- k) Assemble the three protections "M".

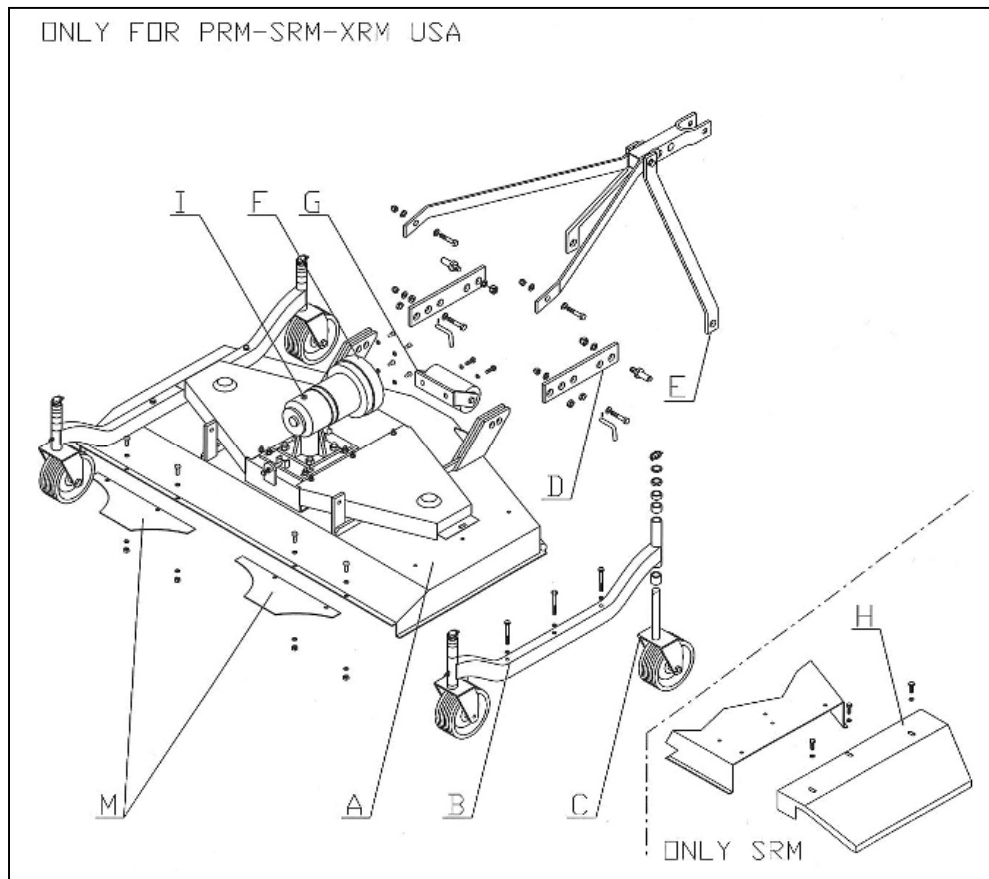

#### 4. "PRM USA" ASSEMBLING

- l) Assemble on frame "A" the two wheel brackets "B" and the four wheels "C".
- m) Assemble on frame "A" the extensions "D", the hitch group "E" and, if bought, the front roll "G".
- n) Assemble on gear box the safety protection "F" and through plug "I" fill oil in foreseen type and quantity (see page 12).
- o) Assemble the two protections "M".

#### 5. "SRM USA" ASSEMBLING

- p) Assemble on frame "A" the two wheel brackets "B" and the four wheels "C".
- q) Assemble on frame "A" the extensions "D", the hitch group "E", the discharge carter "H".
- r) If supplied, assemble on frame "A" the front roll "G".
- s) Assemble on gear box the safety protection "F" and through plug "I" fill oil in foreseen type and quantity (see page 12).

#### 6. "XRM USA" ASSEMBLING

- t) Assemble on frame "A" the two wheel brackets "B" and the four wheels "C".
- u) Assemble on frame "A" the extensions "D", the hitch group "E" and the front roll "G".
- v) Assemble on gear box the safety protection "F" and through plug "I" fill oil in foreseen type and quantity (see page 12).
- w) Assemble the three protections "M".



## INSTRUCTIONS FOR USE

### 1. BEFORE BEGINNING WORK

- a) Check oil level in gear box. (See page 12 point "2")
- b) Hook the machine to the tractor.
- c) With the machine raised, go to the work area.
- d) If necessary regulate the cutting height as follows:
  1. Remove the spring pin from the pivotal axle.
  2. Move the distance washer above or below the hub.
  3. Reposition the spring.
  4. Make sure that the same cutting height is set up on each wheel of all cutting components.

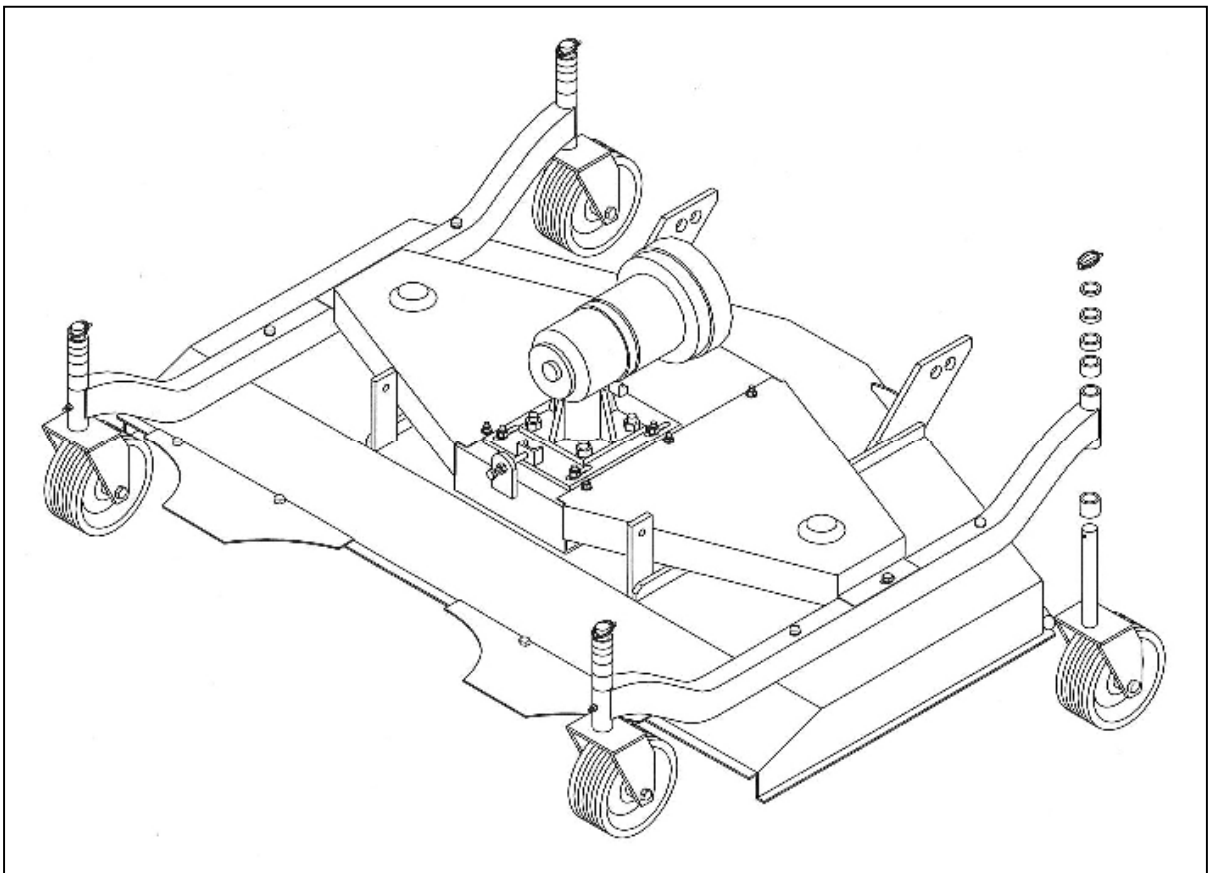

- e) Connect the PTO shaft to mowers P.T.O.
- f) Check that the PTO chain is attached to the dragging hook so as to prevent the protection sheath of the PTO from rotating.

## **2. TO BEGINNING WORK**

- a) Keep people, animals and things at least 15 meters from the machine. Start the engine and lower the 3 cutting components as follows:
- b) Insert the PTO gradually bring it to 540 r.p.m.
- c) Begin cutting.

## **3. AT THE END OF CUTTING OPERATIN**

- a) Stop the tractor.
- b) Switch off the tractor PTO.
- c) Disconnect the PTO shaft.
- d) Raise the machine.
- e) Clean the under sides of the cutting components to remove deposits of grass and dirt. Use a wooden spatula so as not damage the paint.
- f) Proceed to a visual check of the blades to make sure if there are damages.

<b>MAINTENANCE INSTRUCTIONS</b>
---------------------------------

On diagram "A" the maintenances are indicated with their terms to effect on the machine.  
 Not follow the scheduled terms can compromise the functionality of the machine and in this case the warranty is not applicable.

**DIAGRAM "A" SCHEDULED MAINTENANCE**

	<b>FIRST START</b>	<b>AFTER 10 H.</b>	<b>EACH 30 H.</b>	<b>EACH 500 H.</b>	<b>END SEASON</b>	<b>BEGINNING WORK</b>	<b>END WORK</b>
<b>MACHINE</b>	Greasing		Greasing		Cleaning Greasing		Cleaning
<b>OIL</b>	Fill	Check level	Check level	Substitution		Check level	
<b>SCREWS</b>		Locking	Locking				
<b>BLADES</b>			Check Sharpness Balance				Check Cleaning
<b>BELTS</b>		Check tension		Substitution			

## 1. GREASING

All the greasing points, both those situated and both centralized, are equipped with greaser HYDRAULIC TYPE MODEL "A" UNI 7663.

To grease use only MULTIFUNCTIONAL GREASE LITHIUM BASED Type NLGI 2.

Refer to diagram, greasing points are: points "C" one per each wheel, point "D" one per each blade, accessible removing the two belts safety carters.

If is assembled the centralized lubrication points "D" are located on a bracket in front of gear box bracket.

Greasing operation must be made at the terms scheduled on diagram "A".

## 2. OIL CHECK - OIL SUSTITUTION

To fill and to change oil use only OIL SAE 140 EP, oil capacity of angular gear box is 0,5 L.

Oil fills and oil change operations must be made at the terms scheduled on diagram "A".

a) To check oil level in angular gear box operate as follows :

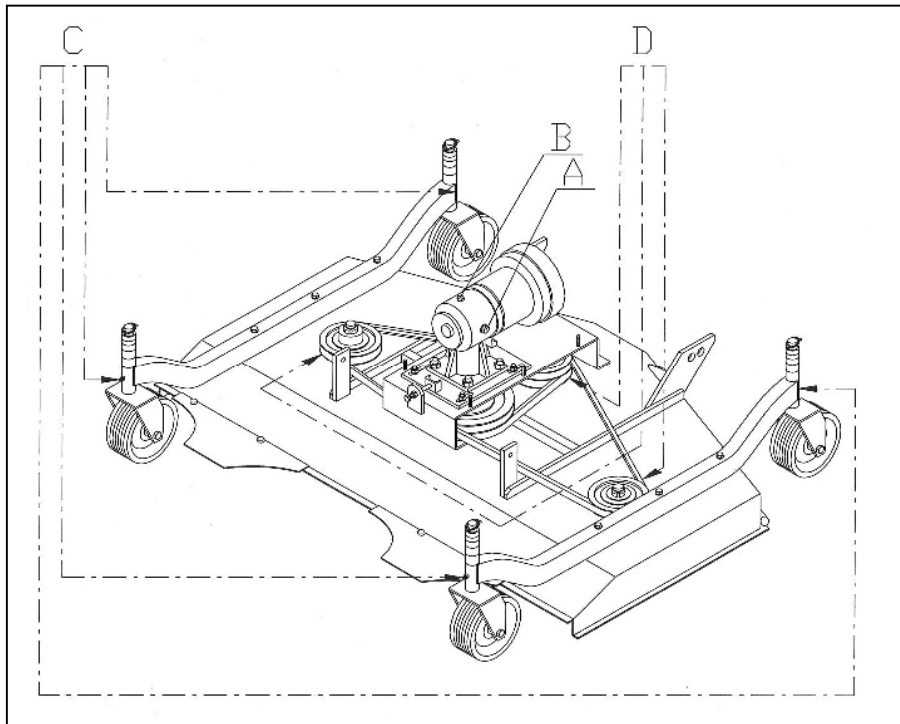

1. With the cutting machine on level, unscrew level plug "A", then check that oil touches on lower hole rim.
2. If level its ok screws the plug "A".
3. If level its low unscrews plug "B" and fill oil.
4. When level its ok screw plugs "A" and "B".

b) To change oil in angular gear box operate as follows :

1. Unscrew plugs "A", "B".
2. Take away oil through hole "B" using a suitable little pump.
3. Put new oil through plug "B".
4. When level its ok screw plugs "A" e "B".

### 3. BELTS ADJUSTING AND SUBSTITUTION

To adjust the tension or substitute the transmission belts operate as follows :

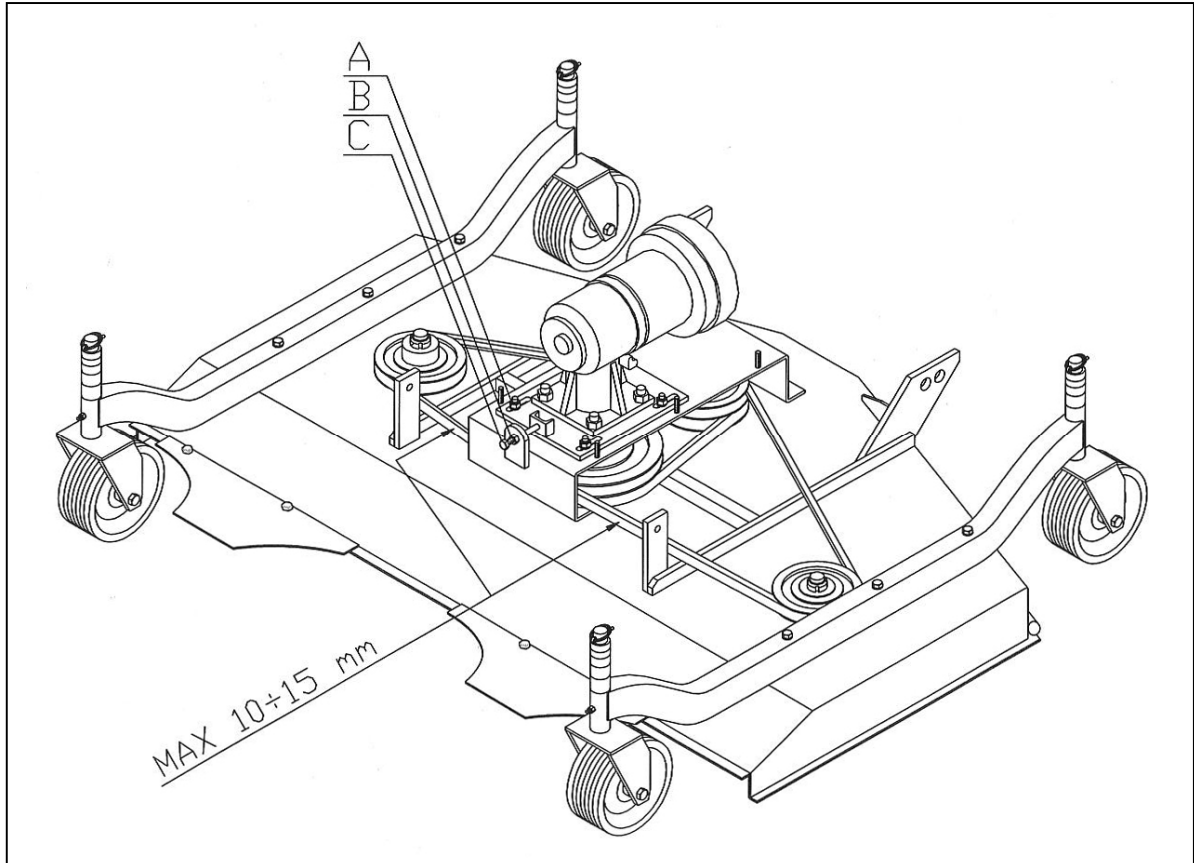

- a) Remove the two upper protection of the cutting component unlocking the fixing screws.
- b) Unlock the 4 screws "A" and nut "B".
- c) To substitute the belts, turn the screw "C" in counter clockwise direction.
- d) Remove the old belt and substitute it with a new one referring to the characteristics in the SPARE PART LIST.
- e) Turn the screw "C" in clockwise direction until to obtain the required tension. The best tension is when pushing with a hand on the belt, this subsides of 10-15 mm, screw nut "B".
- f) To adjust only the tension of the belt, don't read step "d".
- g) Lock the screws "A".
- h) Reassemble the protection.

## 7. BLADE SUBSTITUTION

To substitute the blades or to make operations of sharpness and/or balancing operate as follows:

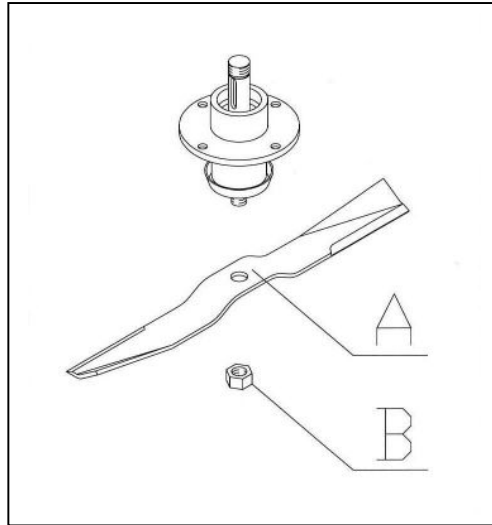

- a) Bring mower in raised position and make sure that the transmission be disconnected.
- b) Take stopped the blade with one hand.
- c) Unscrew the stop ring nut "B".
- d) Remove the blade "A" from its seat and substitute it with a new one or make the operations of sharpness and balancing.
- e) Insert the new blade "A" in its seat.
- f) Take stopped the blade with one hand.
- g) Screw the stop ring nut "B" making sure to lock it very much.

### NOTE:

**Every time that you disassemble the blade from the spindle you must substitute also the self locking nut.**

**PROBLEMS SOLVING**

<b>TROUBLES</b>	<b>CAUSES AND SOLUTIONS</b>
<b>Abnormal vibrations</b>	<ul style="list-style-type: none"><li>-Damaged blade - Replace</li><li>-Broken blade - Replace</li><li>-Not balanced blade - Balance</li><li>-Damaged bearings – Change</li><li>-Damaged hub – Change</li></ul>
<b>Uneven or unsatisfactory cut</b>	<ul style="list-style-type: none"><li>-Not sharp blade – Sharp</li></ul>

## TRANSPORT

Except when working, moving the machine takes place when the machine is standing still and the transmission is disconnected.

**<Important>**: keep speed low avoiding holes and ground roughness.

**<Important>**: Before begin the movements always make sure that the safety hooks be in position.

**<Note when** on the road, obey existing traffic laws. Exhibit the signal signs on the rear ends. Respect any local laws there may be.

## STORAGE

Store the machine in a dry place that isn't dusty.

## INFORMATION ON DEMOLITION



At the end of its working life, the machine must be sent to be demolished and that can only be done by an authorized authority, in accordance with the national laws in force for the environment. Therefore it is necessary to get information from the qualified local authorities on the procedure to follow. The machine is mainly composed of: iron materials and paints.

## WARRANTY

The machine is covered by the manufacturer warranty for a period of 24 months.

The warranty is not applicable when:

- a) The maintenance work has not been done correctly.
- b) The machine has been used out of its own service.
- c) The machine has been transformed or modified without the manufacturer's written authorization.



**WORK AND MAINTENANCE SHEET**

Every user should register on this sheet the facts about the life of the machine (both work and maintenance), so as to attest its conditions.

<b>DATE</b>	<b>WORKING HOURS</b>	<b>MAITENANCE</b>	<b>NOTE</b>	<b>USER</b>

## **SPARE PARTS AND OPTIONS**

**PRM-FMRD FRAME COMPONENTS**

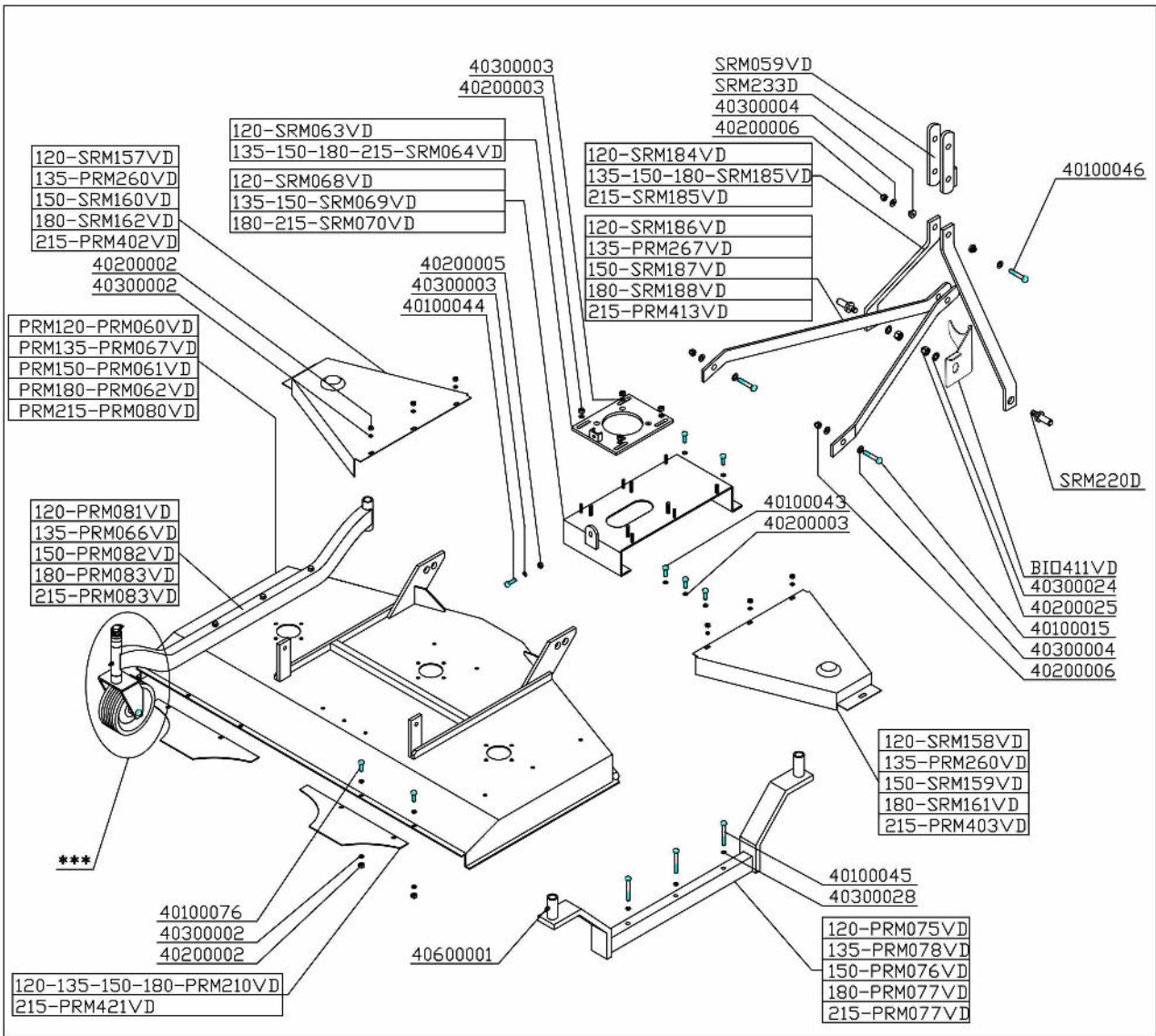

**- \*\*\*- WHEEL BRACKET / WHEEL JOINT**

Mower type	Rubber wheel Ø 210		Rubber wheel Ø 310		Tire wheel Ø 330	
	Wheel code	Wheel bracket code	Wheel code	Wheel bracket code	Wheel code	Wheel bracket code
PRM 120 FMRD 120	SRM071D	PRM063VD	SRM116D	PRM075VD	SRM115D	PRM075VD
PRM 135 FMRD 135	SRM071D	PRM066VD	SRM116D	PRM078VD	SRM115D	PRM078VD
PRM 150 FMRD 150	SRM071D	PRM065VD	SRM116D	PRM076VD	SRM115D	PRM076VD
PRM 180 FMRD 180	SRM071D	PRM064VD	SRM116D	PRM077VD	SRM115D	PRM077VD
PRM 215	SRM071D	PRM064VD	SRM116D	PRM077VD	SRM115D	PRM077VD
Standard	X					
Option			X		X	

NOTE: For wheels spare parts see page 25.

## SRM-FM FRAME COMPONENTS

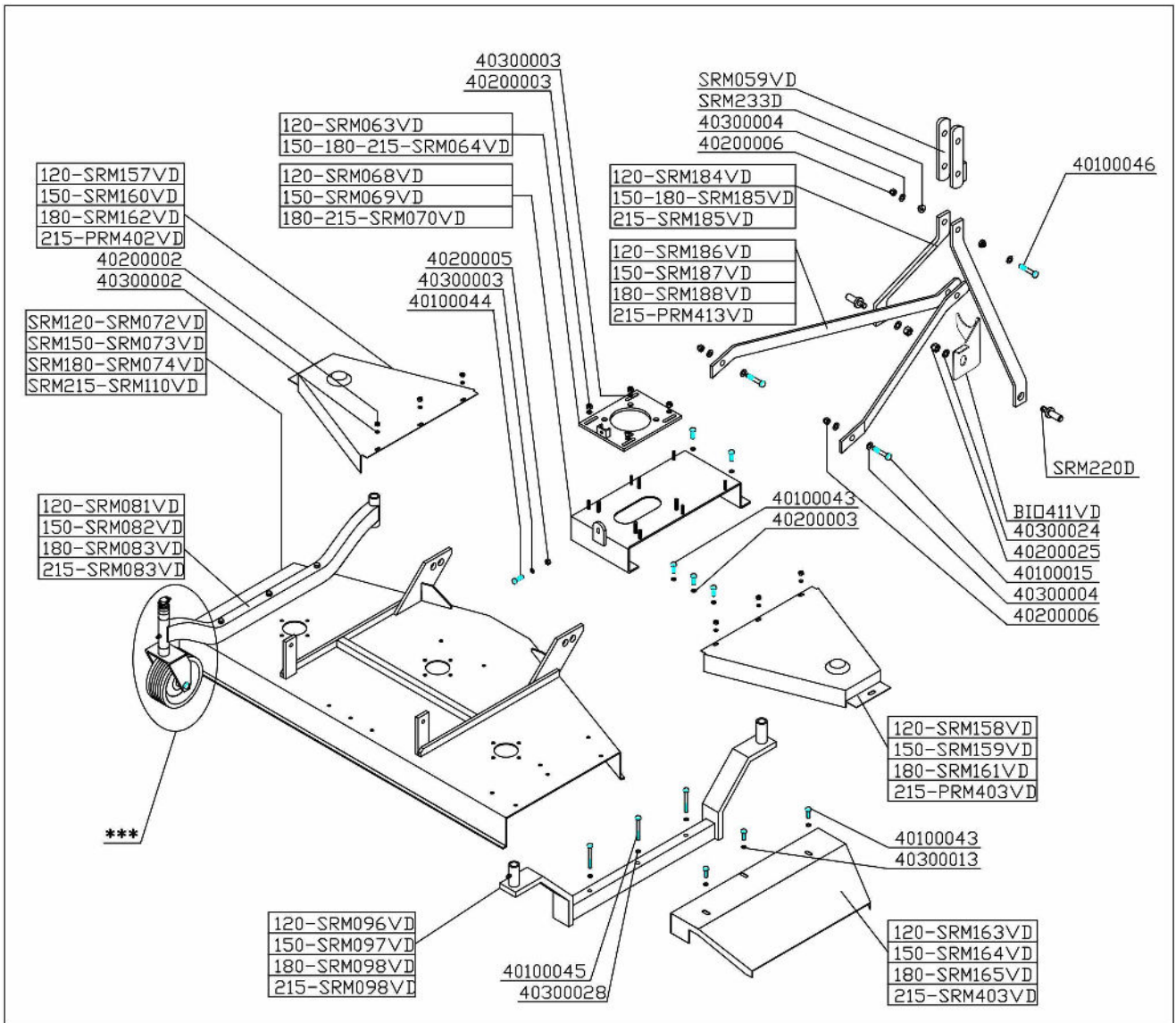

### - \*\*\*- WHEEL BRACKET / WHEEL JOINT

Mower type	Rubber wheel Ø 210		Rubber wheel Ø 310		Tire wheel Ø 330	
	Wheel code	Wheel bracket code	Wheel code	Wheel bracket code	Wheel code	Wheel bracket code
SRM 120 FM 120	SRM071D	SRM060VD	SRM116D	SRM096VD	SRM115D	SRM096VD
SRM 150 FM 150	SRM071D	SRM061VD	SRM116D	SRM097VD	SRM115D	SRM097VD
SRM 180 FM 180	SRM071D	SRM062VD	SRM116D	SRM098VD	SRM115D	SRM098VD
SRM 215	SRM071D	SRM062VD	SRM116D	SRM098VD	SRM115D	SRM098VD
Standard	X					
Option			X		X	

NOTE: For wheels spare parts see page 25.

## XRM-XFM FRAME COMPONENTS

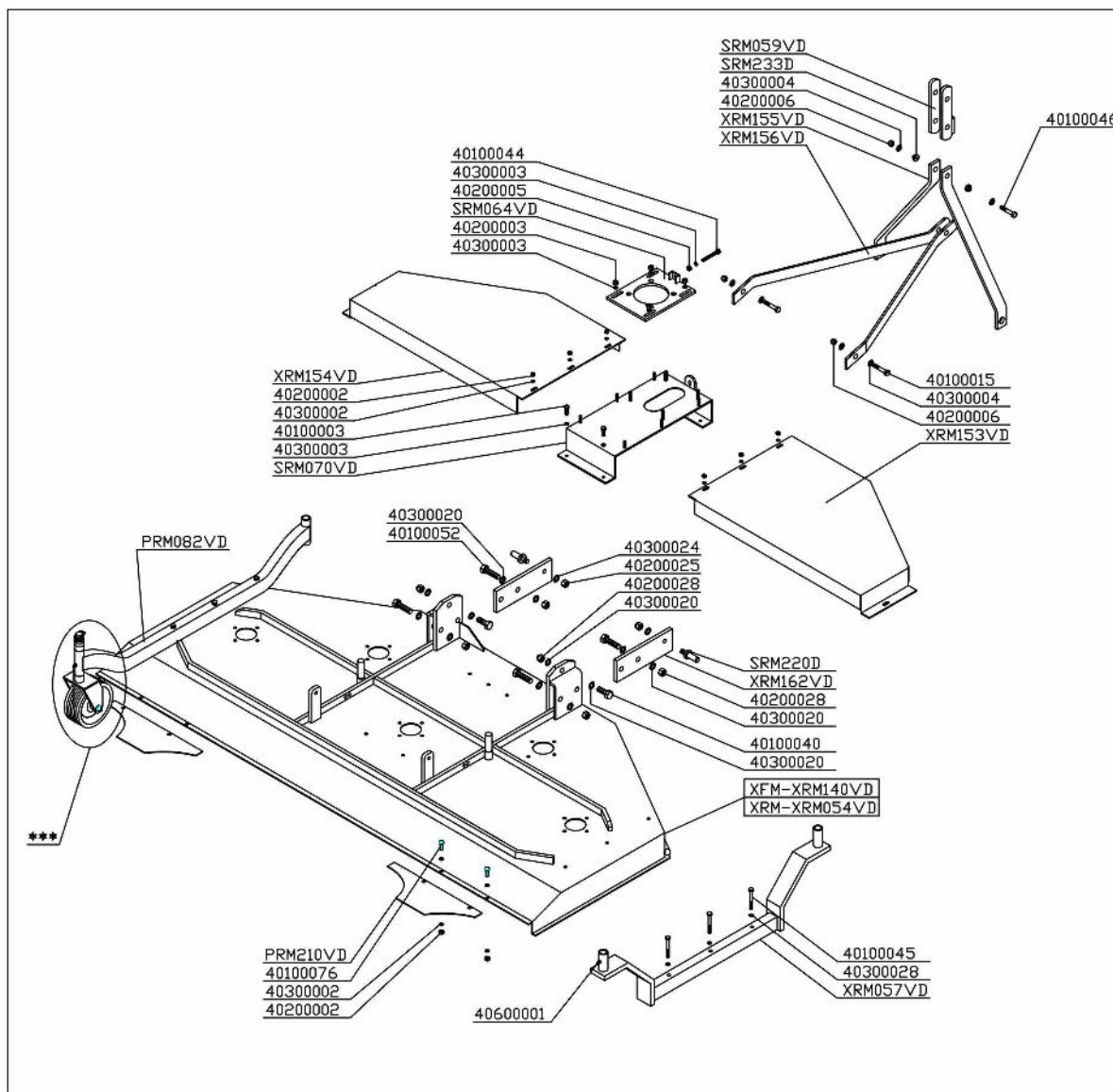

- ***- WHEEL BRACKET / WHEEL JOINT						
	Rubber wheel Ø 210		Rubber wheel Ø 310		Tire wheel Ø 330	
Mower type	Wheel code	Wheel bracket code	Wheel code	Wheel bracket code	Wheel code	Wheel bracket code
XRM XFM	SRM071D	PRM065VD	SRM116D	XRM057VD	SRM115D	XRM057VD
Standard	X					
Option			X		X	

NOTE: For wheels spare parts see page 25.

USA OPTION FRAME COMPONENTS

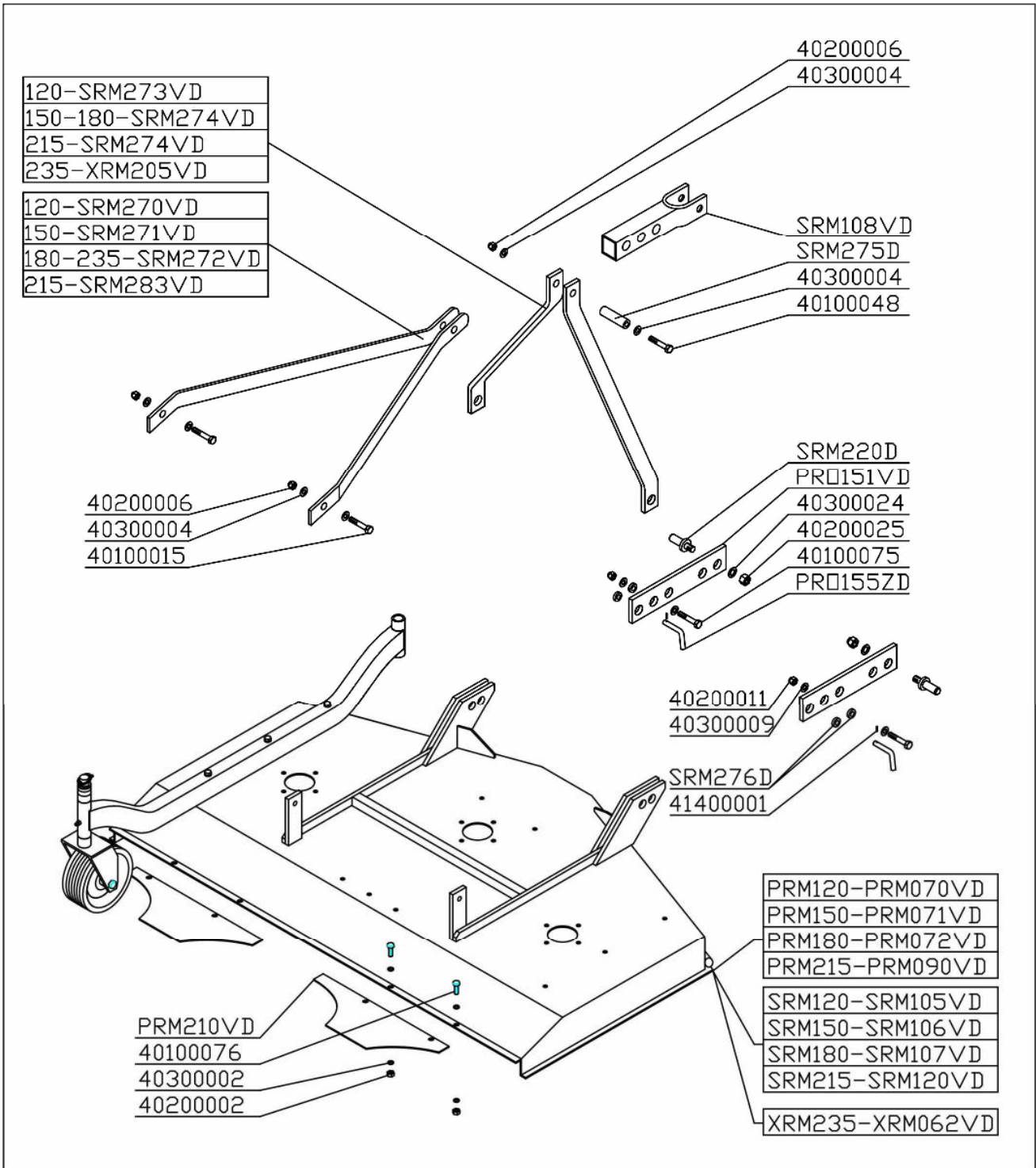

PRM-FMRD-SRM-FM TRANSMISSION

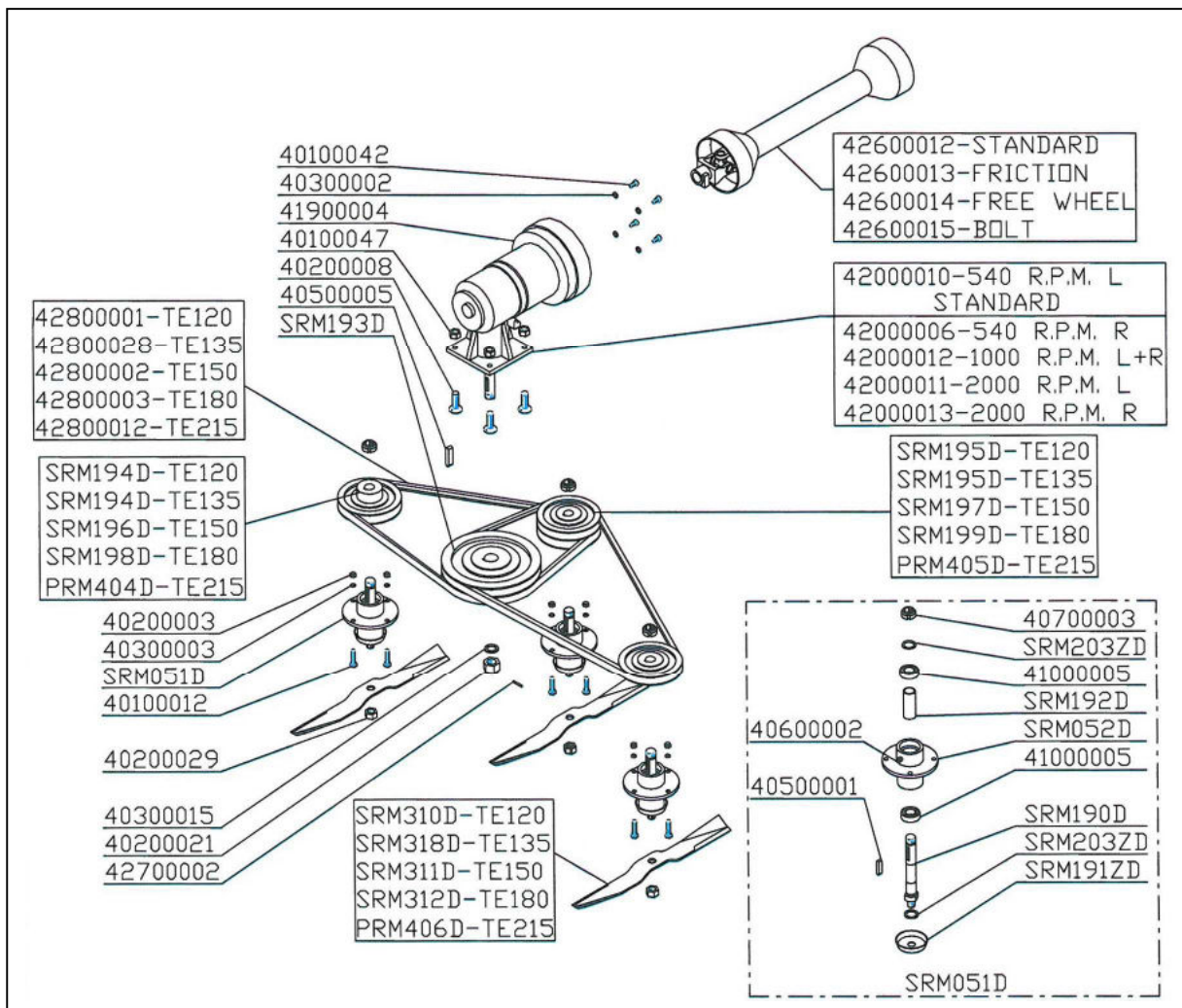

# XRM-XFM TRANSMISSION

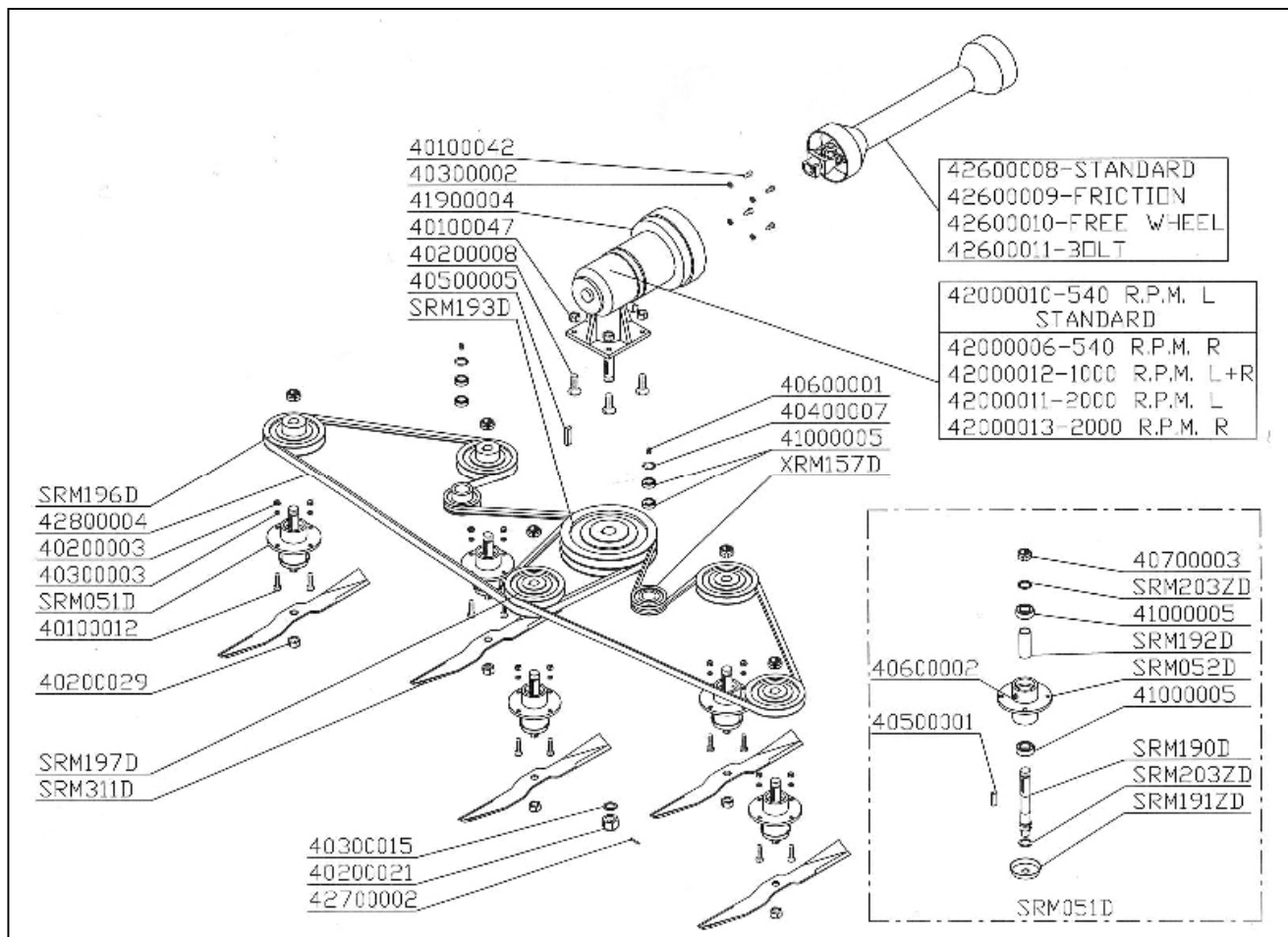



**WHEELS AND FRONT ROLL COMPONENTS**

∅330 - SRM115D

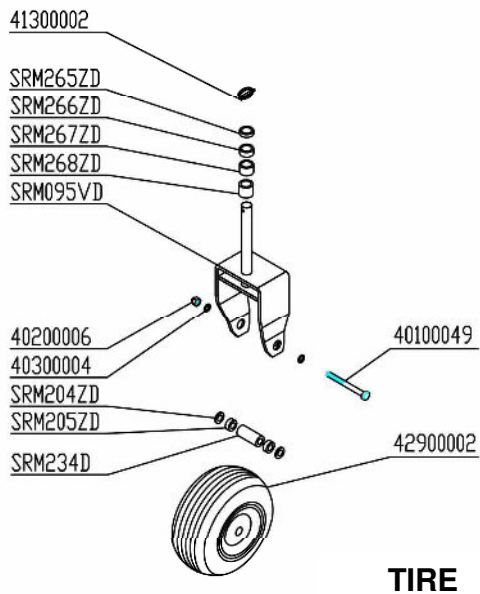

∅310 - SRM116D

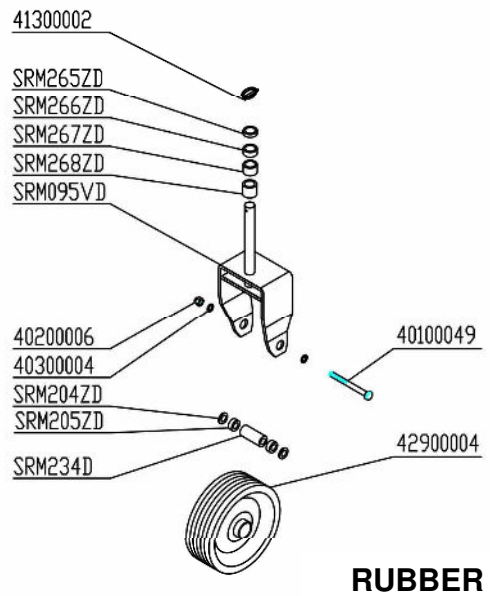

□M100D

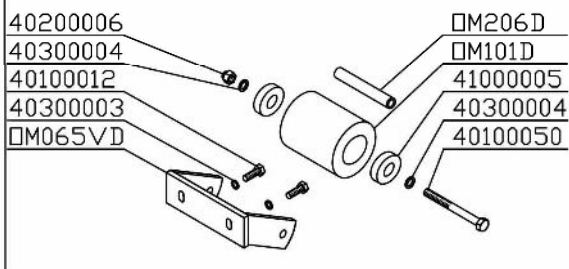

∅210 - SRM071D

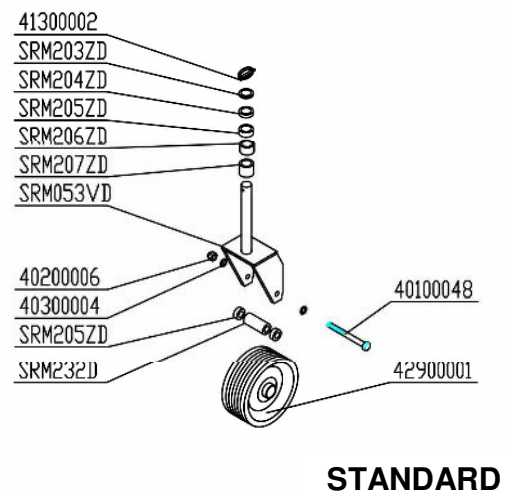

**KIT TO TRANSFORM REAR MOWER IN FRONT MOWER AND VICEVERSA**

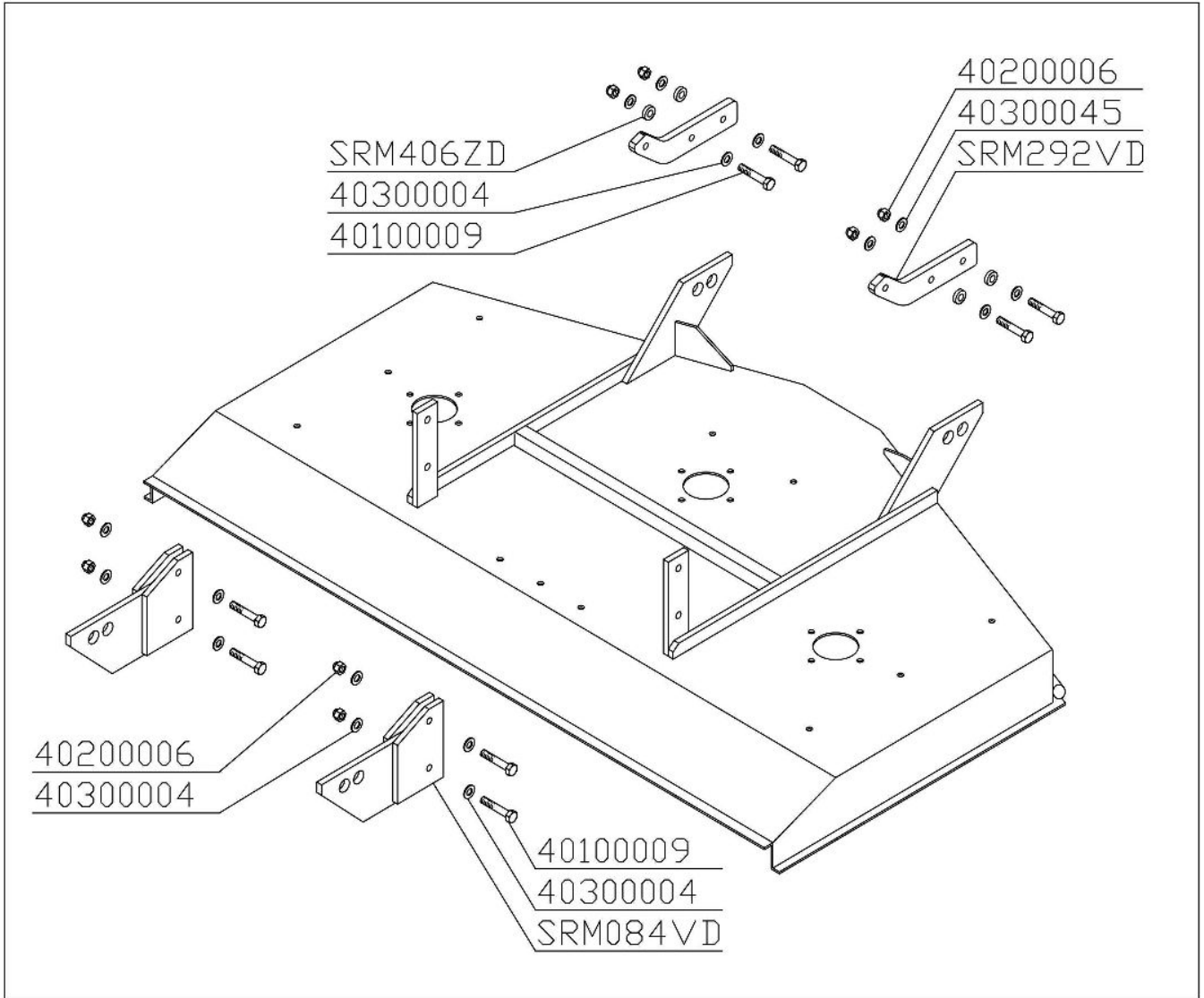

The kit is suitable to transform the rear mowers, rear discharge (PRM) and side discharge (SRM), into front mowers, rear discharge (FMRD) and side discharge (FM).  
The kit is the same for the three dimensions 120, 135, 150 e 180.

**CENTRALIZED LUBRICATION COMPONENTS**

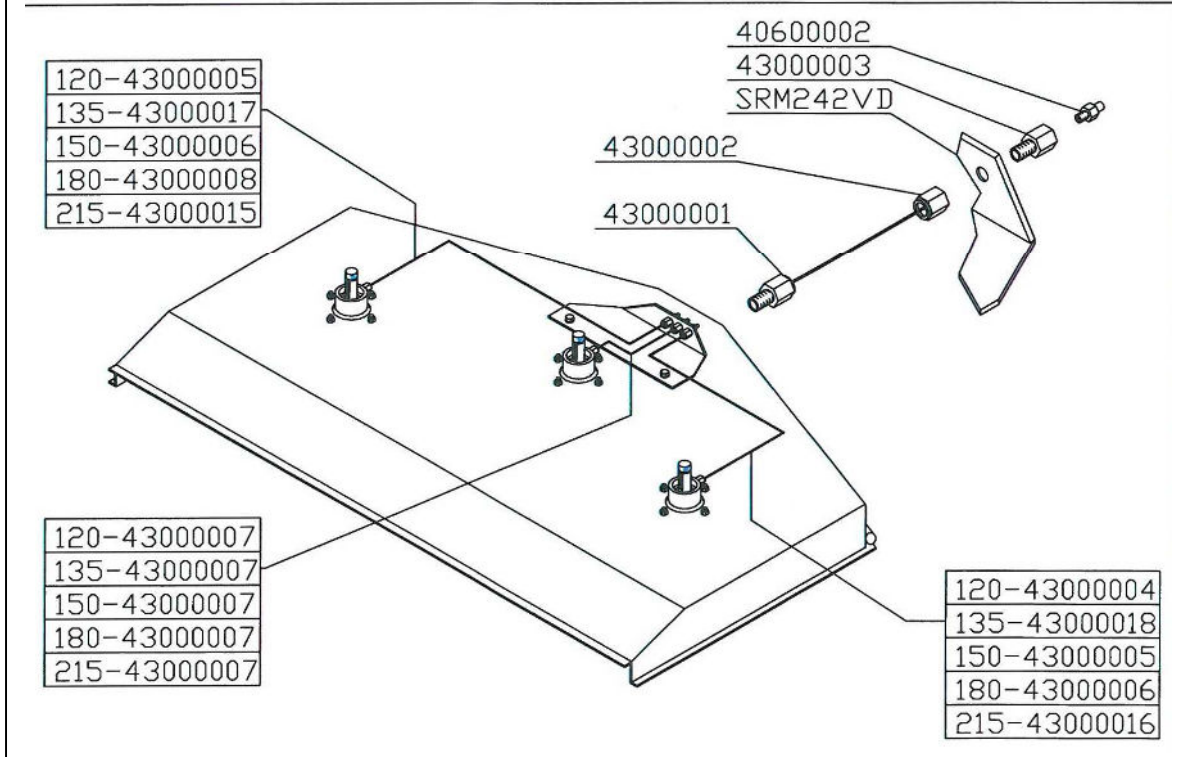
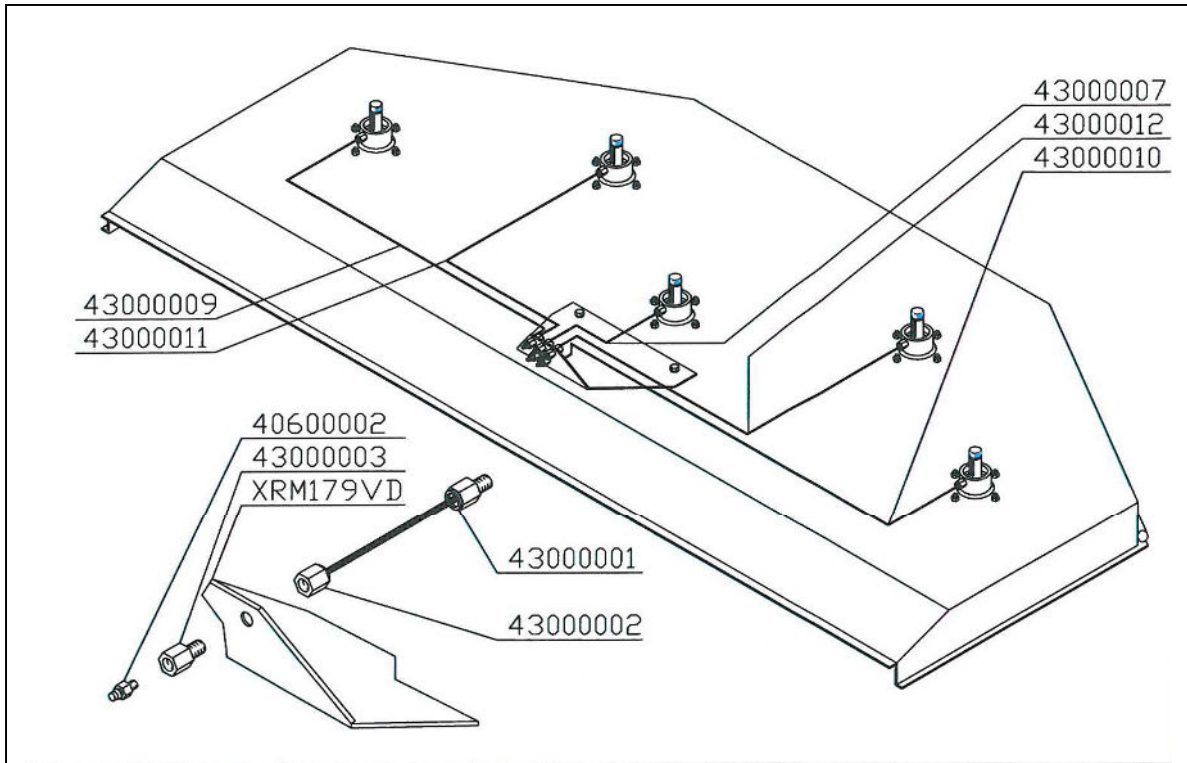

MULCHING KIT

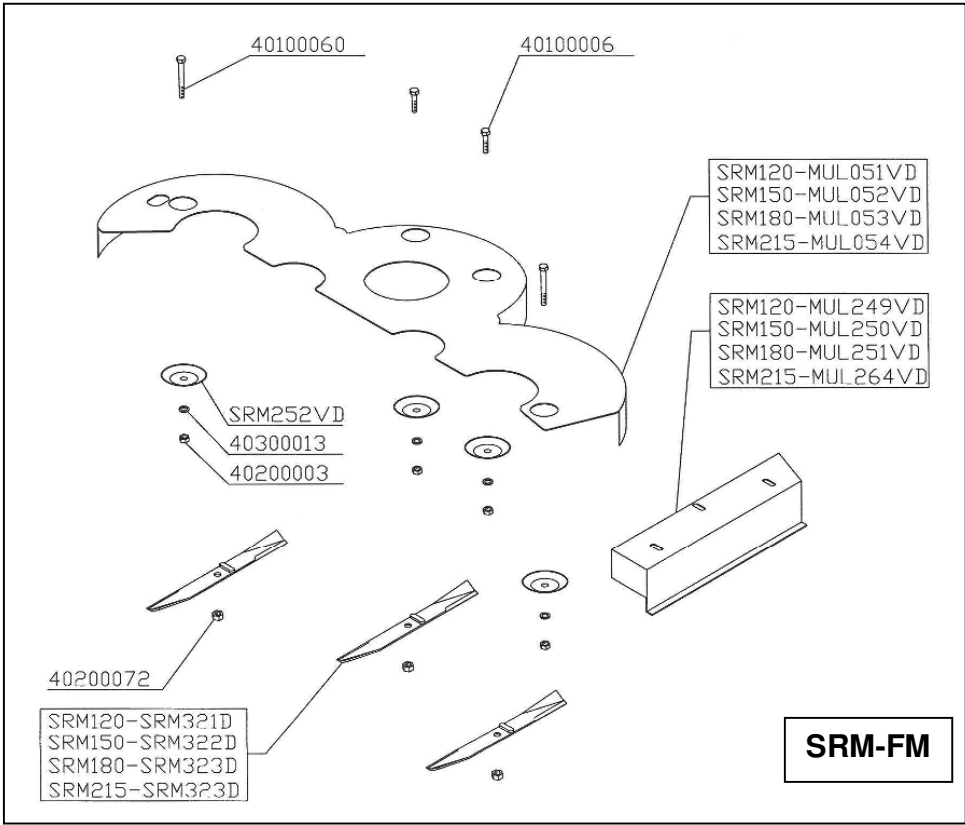
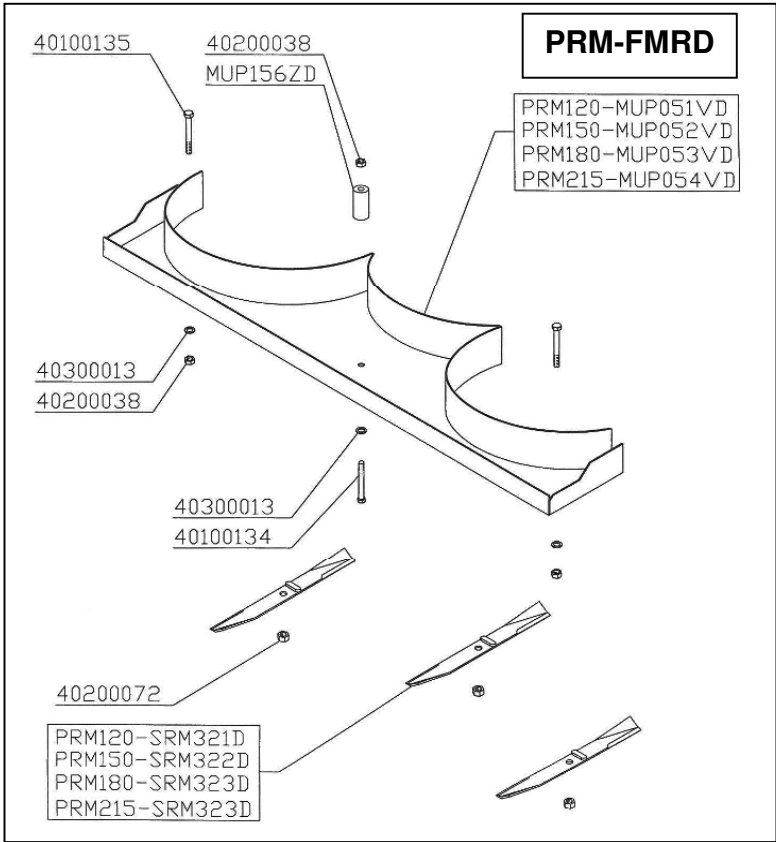

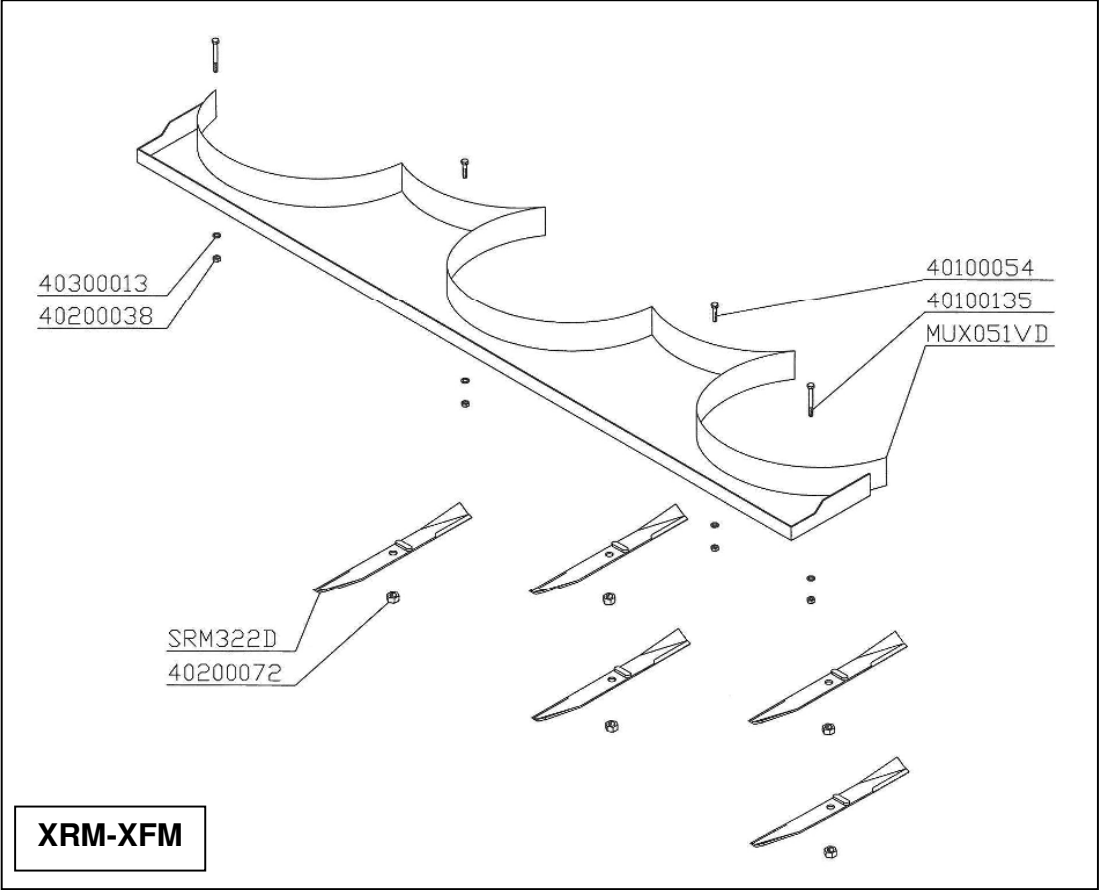

## GENERAL INDEX

<b>PREFACE</b> .....	<b>2</b>
<b>DESCRIPTION</b> .....	<b>3</b>
FUNCTION OF USE .....	3
PERFORMANCES .....	3
PERFORMANCES LIMITS .....	3
STANDARD EQUIPMENT .....	3
VARIANTs & OPTIONS .....	3
<b>TECHNICAL SPECIFICATIONS</b> .....	<b>4</b>
<b>SAFETY INFORMATION</b> .....	<b>5</b>
GENERAL REGULATIONS .....	5
SAFETY RESTRICTIONS .....	5
<b>SAFETY SIGNS ON THE MACHINE</b> .....	<b>6</b>
<b>ASSEMBLING INSTRUCTIONS</b> .....	<b>7</b>
1. "PRM-FMRD" ASSEMBLING .....	7
2. "SRM-FM" ASSEMBLING .....	7
3. "XRM-XFM" ASSEMBLING .....	7
4. "PRM USA" ASSEMBLING.....	8
5. "SRM USA" ASSEMBLING.....	8
6. "XRM USA" ASSEMBLING.....	8
1. BEFORE BEGINNING WORK .....	9
2. TO BEGINNING WORK.....	10
3. AT THE END OF CUTTING OPERATIN .....	10
<b>MAINTENANCE INSTRUCTIONS</b> .....	<b>11</b>
DIAGRAM "A" SCHEDULED MAINTENANCE.....	11
1. GREASING .....	12
2. OIL CHECK - OIL SUSTITUTION.....	12
3. BELTS ADJUSTING AND SUBSTITUTION.....	13
7. BLADE SUBSTITUTION.....	14
<b>PROBLEMS SOLVING</b> .....	<b>15</b>
<b>TRANSPORT</b> .....	<b>16</b>
<b>STORAGE</b> .....	<b>16</b>
<b>INFORMATION ON DEMOLITION</b> .....	<b>16</b>
<b>WARRANTY</b> .....	<b>16</b>
<b>WORK AND MAINTENANCE SHEET</b> .....	<b>17</b>
<b>PRM-FMRD FRAME COMPONENTS</b> .....	<b>19</b>
<b>SRM-FM FRAME COMPONENTS</b> .....	<b>20</b>
<b>XRM-XFM FRAME COMPONENTS</b> .....	<b>21</b>
<b>USA OPTION FRAME COMPONENTS</b> .....	<b>22</b>
<b>PRM-FMRD-SRM-FM TRANSMISSION</b> .....	<b>23</b>
<b>XRM-XFM TRANSMISSION</b> .....	<b>24</b>

<b>WHEELS AND FRONT ROLL COMPONENTS .....</b>	<b>25</b>
<b>KIT TO TRANSFORM REAR MOWER IN FRONT MOWER AND VICEVERSA .....</b>	<b>26</b>
<b>CENTRALIZED LUBRICATION COMPONENTS.....</b>	<b>27</b>
<b>MULCHING KIT.....</b>	<b>28</b>



Dichiarazione CE di conformità ai sensi della Direttiva Macchine 2006/42/CE

CE declaration of conformity under the Machinery Directive 2006/42/CE

Déclaration CE de conformité conforme a la Directive Machine 2006/42/CE

Eg konformitätserklärung im Sinne der Eg Vorschrift Maschine 2006/42/CE

### DEL MORINO S. R. L."

- Via Caroni di Sotto n. 19 -

- 52033 CAPRESE MICHELANGELO (AREZZO) ITALIA -

Dichiara sotto la propria responsabilità che la macchina "TAGLIA ERBA » è conforme ai requisiti di sicurezza e di tutela della salute di cui alla "Direttiva Macchine 2006/42/CE."

Per la verifica delle conformità alla direttiva sopramenzionata sono state consultate le norme armonizzate **UNI EN ISO 12100:2010; 13857:2008; 4254-1:2010; 4254-12:2010.**

Under Its own responsibility declare that the machine "FINISHING MOWER" complies to the safety and health protection requirement of machinery directive **2006/42/CE.**

To verify the conformity to the above mentioned directive, have been consulted the harmonized standards **UNI EN ISO 12100:2010; 13857:2008; 4254-1:2010; 4254-12:2010.**

Déclarons sous notre responsabilité que la machine "TONDEUSE" est conforme aux prescriptions en matière de sécurité et de santé stipulée dans la directive machine **2006/42/CE.**

Pour le contrôle des conformités des directive citées ont été consultées les règles unifiées **UNI EN ISO 12100:2010; 13857:2008; 4254-1:2010; 4254-12:2010.**

Erklärt hiermit in eigener Verantwortung dass der maschine " MÄHWERK " Die Schutzanforderungen und den Gesundheitsschutz, gemäß der **2006/42/CE** einhalt.

Für Überprüfung der Konformität der oben genannten Vorschriften wurden Vorschriften konsultiert **UNI EN ISO 12100:2010; 13857:2008; 4254-1:2010; 4254-12:2010.**

### TAGLIA ERBA - FINISHING MOWER - TONDEUSE - MAHWERK

TYPE	MODEL						
	FM	FMRD	PRM	SRM	XFM	XRM	
120							
135							
150							
180							
215							
235							

Matr. n° : \_\_\_\_\_ Caprese Michelangelo li : \_\_\_\_\_

  
Via Caroni di Sotto, 19 - 52033 CAPRESE MICHELANGELO (AR)  
Tel. 0575 791058 (RA) - Fax 0575 791210  
PORTAL SITE: <http://www.del-morino.it>  
E-mail: [info@del-morino.it](mailto:info@del-morino.it) - [export@del-morino.it](mailto:export@del-morino.it)  
Cap. Soc. 400.000 I.v. IN MECCANOGRAFICO AR 005024  
N° ISCRIZIONE RI, Ccd. Fisc. e P. IVA: 01041010511  
R.L. AREZZO N° REA 81362



Farm & Garden Equipment



Custode del Fascicolo Tecnico: **Dott. A. Del Morino**, Via Caroni di Sotto 19, 52033 Caprese Michelangelo Arezzo Italy.  
Keeper of the technical folder: **Dott. A. Del Morino**, Via Caroni di Sotto 19, 52033 Caprese Michelangelo Arezzo Italy.  
Dépositaire du dossier technique: **Dott. A. Del Morino**, Via Caroni di Sotto 19, 52033 Caprese Michelangelo Arezzo Italy.  
Verwalter der technischen Unterlagen: **Dott. A. Del Morino**, Via Caroni di Sotto 19, 52033 Caprese Michelangelo Arezzo Italy.