

## USE AND MAINTENANCE MANUAL

# FLAIL MOWER MODEL LEVANTE SUPER



## PREFACE

### **This manual is an integral part of the machine**

It must always accompany the machine and be kept within reach of the operator.  
The mentioned attachments are an integral part of this manual.

### **Purpose of the manual**

This manual provides the information necessary for the proper and safe use of the machine.  
The user must read the manual carefully before each use.

### **Responsibility of the user**

The user is responsible for accidents or damage caused to persons or things due to non-compliance of the instructions of this manual.

### **Assistance in the use of the manual**

Explanations: contact the dealer

Delivery of additional copies of the manual: in case of loss or deterioration, or if a copy in a different language is needed, the user can make a request to the dealer or manufacturer.

### **Attention to the warning signals**



**<Danger>**: indicates an imminent dangerous situation which, if not avoided, will cause death or serious damage.



**<Warning>**: indicates a potentially dangerous situation, less serious than the previous one, which, if not avoided, can cause death or serious damage.



**<Caution>**: indicates a potentially dangerous situation which, if not avoided, can cause minor to moderate damage. It also indicates to pay attention while performing a dangerous operation.

**<Important>**: indicates instructions which must be carefully followed to avoid damages to the product, the process or the environment.

**<Note>**: indicates additional information.

<b>DESCRIPTION</b>
--------------------

## **FIELD OF USE**

The hydraulic adjustment system allows the machine to perform several functions, such as cutting grass, stalks, prunings and edges.

The use of a technical constructive concept aimed at reaching high performances, reliability and durability improves the efficiency in terms of power/tractor consumption ratio, thanks to the rigidity of the machine frame, to the shape of the tools, to the perfect dynamic balancing of the rotor and to many others original technical solutions.

## **PERFORMANCE**

The machine is connected to the tractor through the 3-point hitch and a cardan shaft. The first one allows the machine to side-shift, the second one, connected to the tractor PTO, allows the rotation of the shaft.

The hydraulic parallelogram mechanism moves the machine to the right in relation to the axle of the tractor, the hydraulic rotation mechanism tilts the machine in relation to the ground.

The working width is fixed and is determined by the model.

The cutting height is adjustable.

The rear roller regulates the cutting height and compacts the cut material.

## **PERFORMANCE LIMITS**

- ❑ Max speed: 5km/h. Speed higher than that indicated may compromise the integrity of the machine, the quality of the work and the safety of the operator.
- ❑ Max power applicable to the gear box: 46 KW  $\pm$  5% to 540 RPM, depending on the models. Power higher than that indicated can damage the gear box irreparably, especially if you are performing heavy-duty work.

---

## **STANDARD EQUIPMENT**

- **Standard cardan shaft, VI category.**
- **Free wheel device integrated in the gear box.**
- **Transmission with 4 belts.**
- **Rear roller adjustable in 3 positions.**
- **Adjustable skids.**

## **VARIATIONS & OPTIONS**

- **Tools: blades.**
- **Tools: hammers.**

## TECHNICAL FEATURES

### FEATURES PER MODEL

Model	Type	Vers.	Power		Working width		Weight		N° tools	N° RPM Rotor
			HP	Kw	Cm	Inch	Kg	Lbs.	N°	RPM
<b>LEVANTE SUPER</b>	160	C	80-120	44-88	160	63	720	1364	48	2250
	190	C	80-120	44-88	190	75	757	1445	56	2250
	220	C	80-120	44-88	216	85	795	1526	64	2250
<b>LEVANTE SUPER</b>	160	M	80-120	44-88	160	63	720	1364	24	2250
	190	M	80-120	44-88	190	75	757	1445	28	2250
	220	M	80-120	44-88	216	85	795	1526	32	2250

**Version:**

**C = Blades**  
**M = Hammers**

	<b>160</b>	<b>190</b>	<b>220</b>
<b>A</b>	92 cm	92 cm	92 cm
<b>B</b>	93 cm	120 cm	145 cm
<b>C</b>	184 cm	210 cm	236 cm
<b>D</b>	180 cm	180 cm	140 cm
<b>E</b>	217 cm	244 cm	270 cm
<b>G</b>	---	---	---
<b>H</b>	---	---	---
<b>L</b>	135 cm	135 cm	135 cm
<b>α</b>	45°	45°	45°

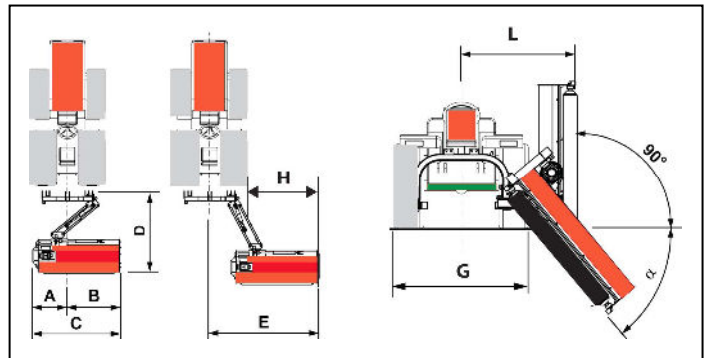

## SAFETY INFORMATION

### GENERAL REQUIREMENTS

- ❑ Work only during daytime.
- ❑ **To prevent damage due to the launch of objects or parts of blades, before starting to work, be sure that no persons or animals are within a radius of 50 meters from the machine.**
- ❑ Wear long trousers and heavy shoes.
- ❑ The protections are integral part of the machine: always work with the protections.
- ❑ Pay attention to the soil: make sure that there are not any stones, sticks, iron wires, etc.
- ❑ Pay attention when using the machine on slopes: proceed in the direction of the maximum slope and never work in slanting direction.
- ❑ Before leaving the driver's seat, turn off the engine and disengage the engine-shaft transmission.
- ❑ Check the machine immediately if it touches foreign objects.
- ❑ Check the machine immediately if there are unusual strong vibrations.
- ❑ Change defective parts quickly.

#### ❑ **ATTENTION – DANGER:**

**The gear box is equipped with a free-wheel device. After disconnecting the PTO, the rotor continues to spin for at least 30 seconds: before approaching the tools make sure that the rotor is stationary.**

#### ❑ **ATTENTION:**

**To prevent damage to the PTO shaft and to the gear box, do not start the machine roughly.**

### RESTRICTIONS OF USE FOR SAFETY

Do not allow children or people who are unfamiliar with the instructions to use the machine.  
Local regulations may restrict the use of the machine on the basis of age.

### RUNNING

The new machine must be broken in. During first use, attach the machine to the tractor, connect the cardan shaft, low the machine down to 15 cm from the ground, then start the PTO and reach 540 RPM gradually. Let the machine run for about 15 minutes. It is normal to hear an hiss coming from the supports, it is due to the adjustment of the protections, it will disappear shortly.

## SAFETY SIGNALS ON THE MACHINE

In this section, the safety signs of the machine are reproduced and explained.



1

2

3

4

5

6

1. Read the manual.
2. Unplug the key from the control panel of the tractor before performing maintenance or repairs.
3. Do not remove the protections.
4. Stay at a safe distance from the cardan shaft.
5. Danger of flying objects. Stay at a safe distance.
6. Stay at a safe distance from the tools when the machine is moving.

### **The safety signs on the machine must be always legible.**

If damaged, the labels must be replaced.

If parts of the machines with the safety signs are replaced, the labels must be replaced as well.

### **Supply of new labels and application procedure**

Contact your dealer to receive new safety labels with instructions for application.

## CHECK THE LENGTH OF THE CARDAN SHAFT

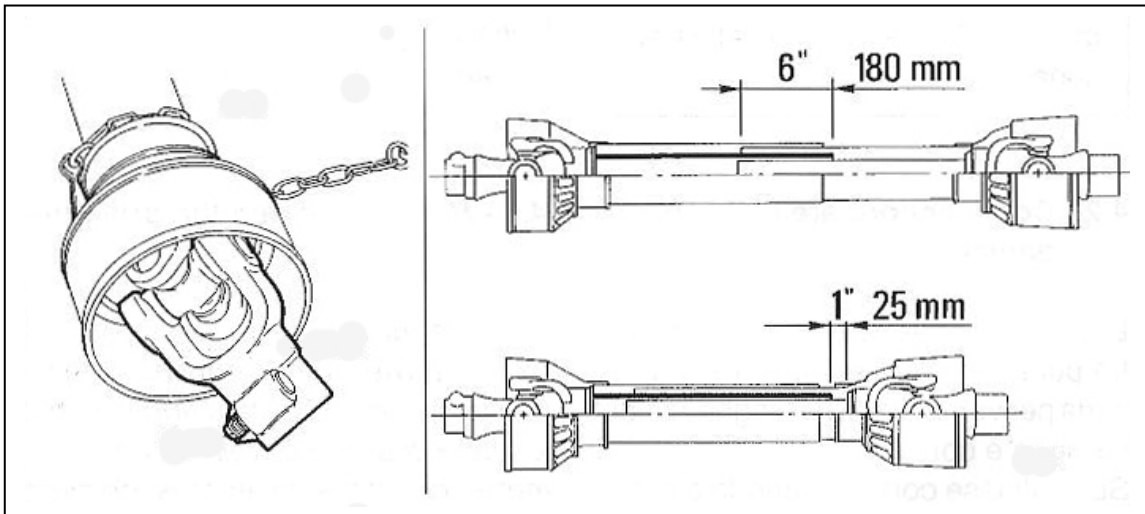

1. After connecting the machine to the 3-point hitch, verify that the tool is in level and centered in relation to the tractor through the adjusting devices.
2. Fit the cardan shaft between the PTO of the tractor and the flail mower.
3. Verify that the length of the cardan shaft is correct.
4. To do so, check what follows: the minimum coupling distance between the inner and outer tube is not less than 180mm in every working position; at the same time, when minimally extended, the cardan shaft can still move by at least 25mm.
5. If the minimum coupling distance is less than 180mm, the cardan shaft is short and must be replaced with a longer one.
6. When minimally extended, if the cardan shaft can move by less than 25 mm, then it is long and therefore it is necessary to shorten it.
7. **ATTENTION:** shortening the cardan shaft is complicated, the operation must be carried out carefully following the instructions in the next chapter, otherwise the cardan shaft itself may be damaged irreparably.

## HOW TO SHORTEN THE CARDAN SHAFT

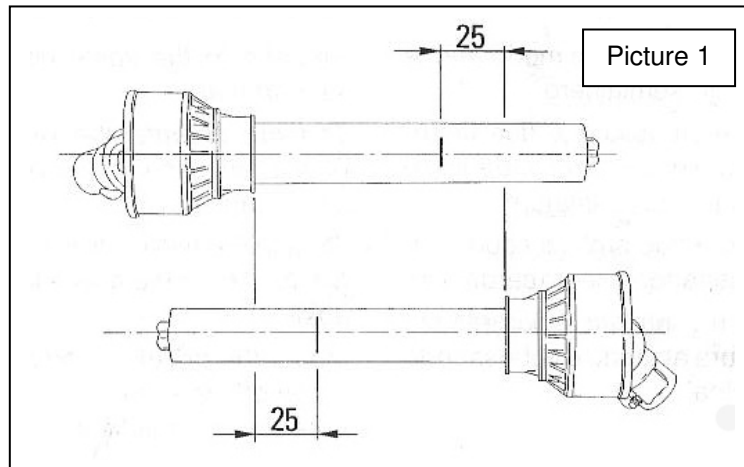

1. Through the hydraulic lift, bring the machine at the minimum distance from the tractor.
2. In this position, block the lift and turn off the engine.
3. Pull out the two parts of the cardan shaft completely.
4. Insert the female semi-cardan (tube with larger diameter) in the PTO of the tractor.
5. Insert the male semi-cardan (tube with smaller diameter) in the PTO of the machine.
6. With the two parts parallel, use a felt pen to mark the cutting point, as shown in picture "1".

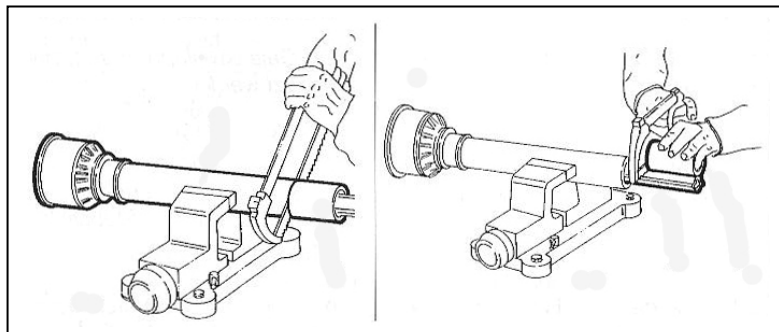

1. Cut the plastic tube with a hacksaw on the line you previously marked on one of the semi-cardan.
2. Align the piece of tube you just cut at the end of the metal tube and then cut it.
3. Repeat the same operations on the other section of the cardan shaft.
4. Use a file to smooth down the edges of the metal tubes.
5. Clean and grease the two metal tubes and then insert one section into the other.
6. Mount the cardan shaft between the tractor and the machine, then verify the length again.



## INSTRUCTIONS FOR USE

### FIRST START

Unpack the machine and place it on a flat and hard surface. Put the machine next to the rear side of the tractor.

**ATTENTION:** the machine must be connected to an agricultural tractor with power between 80 and 120 HP, with 4 hydraulic connections on the back.

a) Attach the machine to the tractor as follows:

1. Remove the spring pins from the two lower connection pins.
2. Insert the lifting arms of the tractor in the lower pins and then block them with the safety spring pins. Alternatively, if the lifting arms of the tractor are equipped with quick coupling, mount the ball joints on the lower pins, lock the pins with the safety spring pins then activate the lifter to hook the machine.
3. Connect the 3-point hitch of the tractor to the 3-point hitch of the machine (the apex) with the corresponding tie-rod, insert the pin and lock with the spring pin.
4. Connect the 4 hydraulic tubes to the quick coupling system of the tractor.
5. Pull out the two safety pins and then remove the block bar "A".
6. Make sure that rotation blocking pin "B" is positioned as shown in Picture 1. Once the security pin has been removed, remove the side-shift blocking pin "C" as well and place it in the slot "C1".
7. Connect the PTO of the tractor to the cardan shaft of the machine. Verify that the security chains are fixed to prevent the cover of the cardan shaft protection from rotating.
8. Start the engine of the tractor, lift the machine from the ground, start the tractor PTO then side-shift and rotate the machine repeatedly to eliminate air from the hydraulic system.

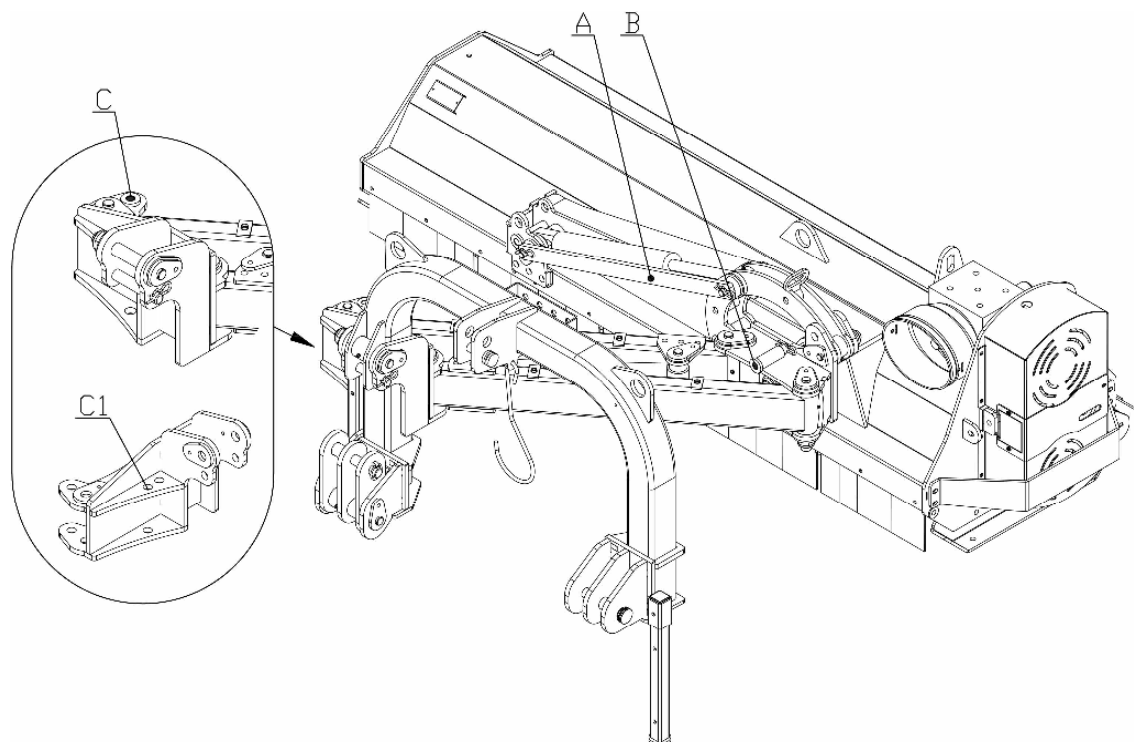

According to the needs of the customer, it is possible to adjust the speed of the hydraulic cylinder of both the side-shifting and rotating system, with the regulator mounted on the connection between the hydraulic tube and the bottom plate of each cylinder.

After eliminating the air from the hydraulic system, rotate the machine upwards and downwards. If you need to adjust the speed of the movement, after unscrewing the locking nut "D", rotate the screw "V" clockwise to decrease or anticlockwise to increase the speed. Repeat the procedure until reaching the desired speed, then block the screw "V" tightening the blocking nut "D".

Repeat the same procedure to regulate the speed of the side-shift cylinder.

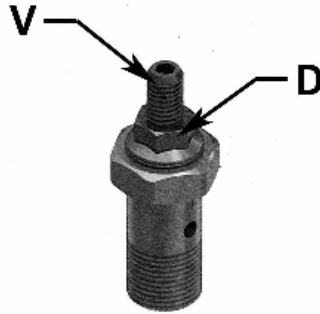

## BEFORE STARTING TO WORK

b) Adjust the skids and the roller as follows:

1. Unscrew the 2 screws "B" and "C" and remove them.
2. Choose one of the four possible positions for skid "A", moving it downwards or upwards. The distance between a hole and the next one is 22,5mm.
3. Reposition the screw "B" and "C" and tighten them.
4. Repeat the same operations on the other side of the machine, making sure that the two skids are adjusted in the same way.
5. Loosen the screw "E", unscrew the screw "F" and remove it.
6. Choose one of the three possible positions for the roller support "D", moving it downwards or upwards.
7. Reposition screw "E", then tighten screw "E" and "F".
8. Repeat the same operations on the other side of the machine, making sure that the two supports are adjusted in the same way.

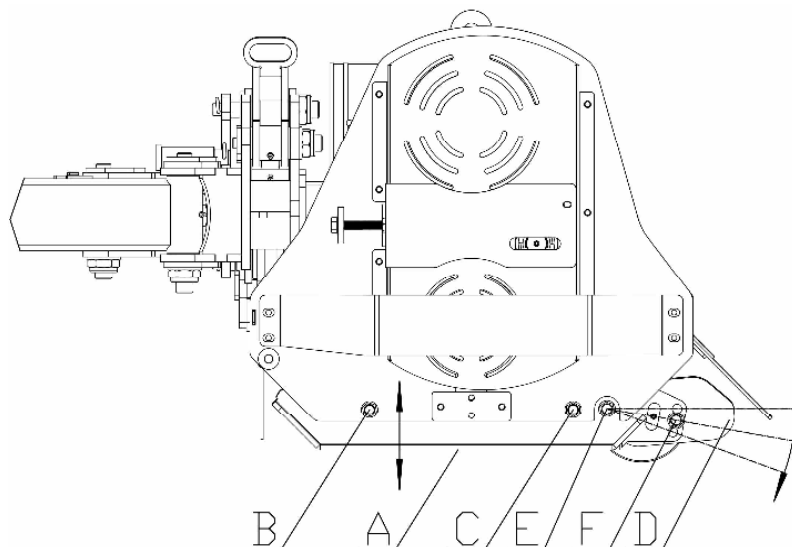

## MOVING AROUND THE WORKING AREA

c) After attaching the machine to the tractor, set it up for transportation as follows:

1. Rotate the machine to the vertical position and shift it towards the center of the tractor.
2. Position the rotation blocking pin "A" as shown in the picture then block it with the safety pin.
3. Position the side-shift blocking pin "B" as shown in the picture then block it the safety pin.
4. Make sure that the piston blocking pin "C" and the 3-point blocking pin "D" are in position and locked as shown in the picture.
5. Proceed to the working area at a moderate speed with the machine fully lifted.

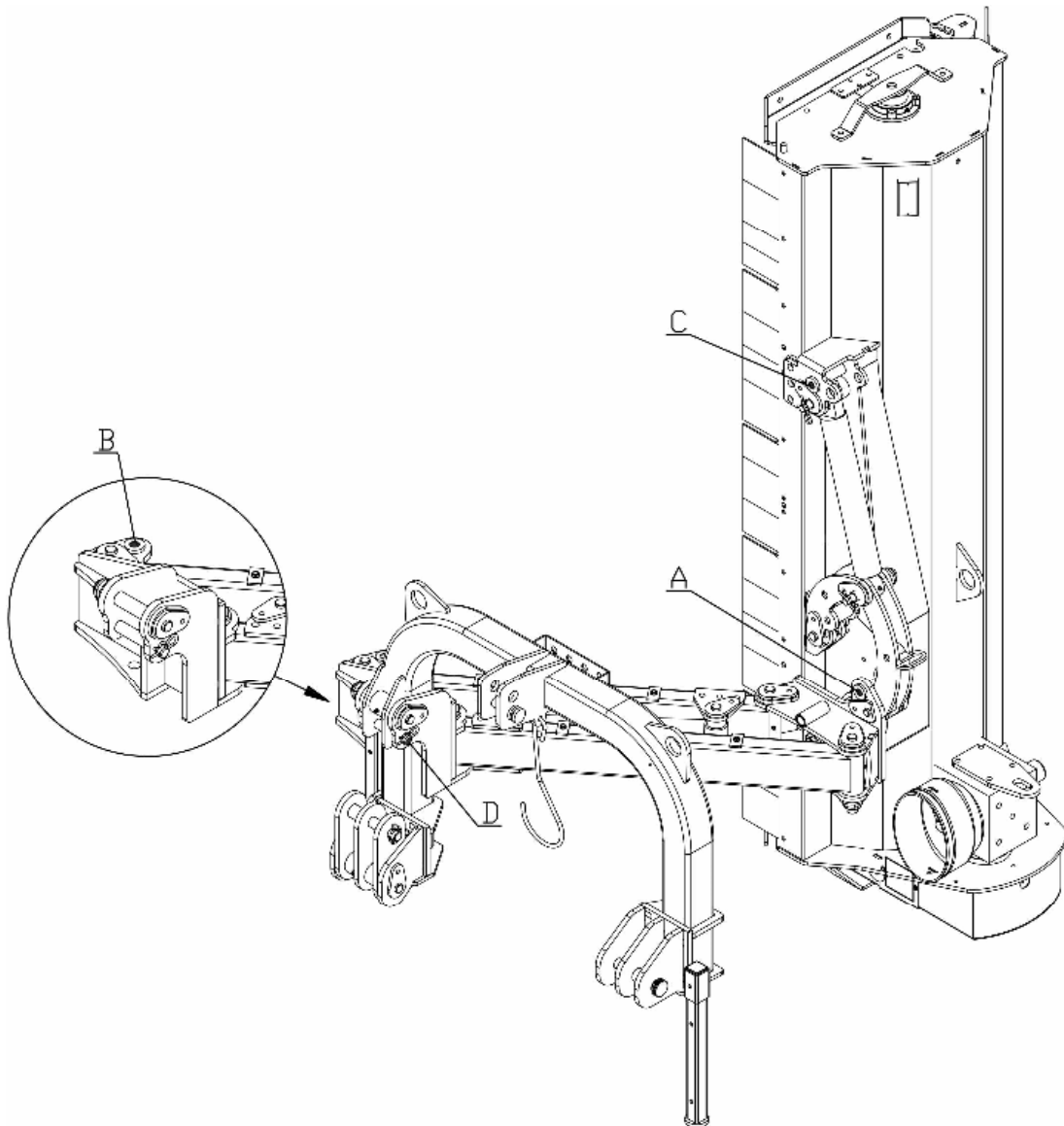

## START WORKING

d) Set up the machine as follows:

1. Remove the rotation blocking pin "A", position it as shown in the picture then block it with the safety pin.
2. Remove the side-shift blocking pin "B", position it in the corresponding support "B1", then block it with the safety pin.
3. If want the machine to automatically adapt to the diagonal undulations of the ground, remove the pin "C" and insert it in the slot "C1".
4. If want the machine to automatically adapt to the longitudinal undulations of the ground, remove the pin "D" and insert it in the slot "D1".

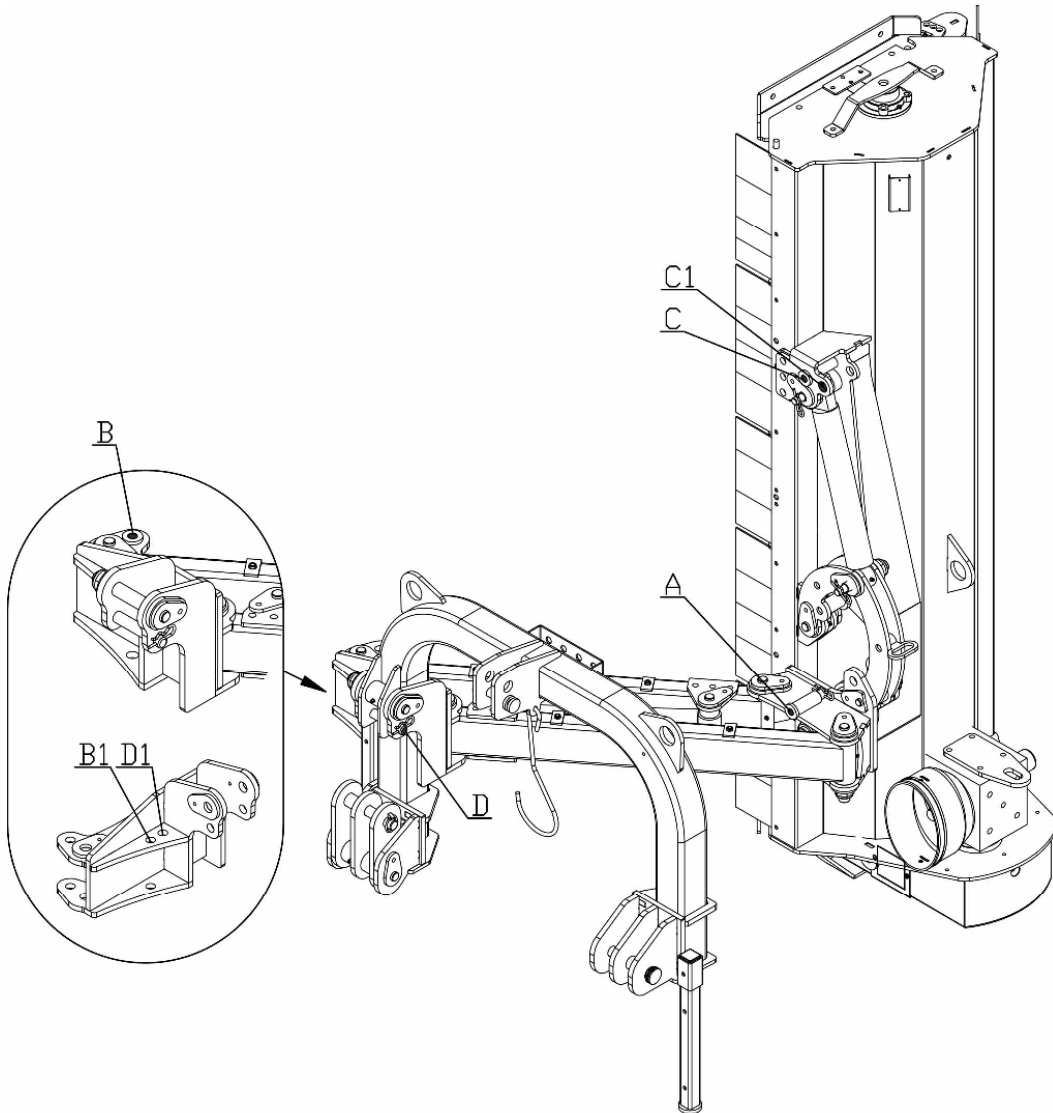

- e. Make sure that there is no one within a radius of 50 m around the machine.
- f. Connect the PTO and reach the expected rotation regime gradually.
- g. Lower the machine until the rear roller leans on the ground.
- h. Start working.

## **AT THE END OF THE WORK**

- a) Stop the tractor and wait for at least 30 seconds until the rotor is completely stopped.
- b) Lift the machine from the ground.
- c) Disconnect the PTO.
- d) Disconnect the cardan shaft from the PTO of the tractor.
- e) Lift the machine completely.
- f) Set up the machine for transportation (see point C).

<b>MAINTENANCE INSTRUCTIONS</b>
---------------------------------

Maintenance operations and their corresponding deadlines are listed in the sheet "A".  
 The noncompliance of the scheduled deadlines compromises the proper functioning of the machine, thus voiding the guarantee.

**SHEET "A" SCHEDULED MAINTENANCE**

	<b>FIRST START</b>	<b>AFTER 10 H</b>	<b>EVERY 30 H</b>	<b>EVERY 500 H</b>	<b>END OF THE SEASON</b>	<b>BEGINNING OF WORK</b>	<b>END OF WORK</b>
<b>MACHINE</b>	Greasing		Greasing		Cleaning Greasing		Cleaning
<b>GEAR BOX</b>	Oil level	Topping	Oil level	Oil change			
<b>SCREWS</b>		Tightening	Tightening				
<b>TOOLS</b>			Check		Check	Check	Check
<b>BELTS</b>		Check Tension		Replacement			

## 1. GREASING

Grease the 18 points from "A" to "U" as indicated in the sheet "A".

Greasing points are equipped with a hydraulic greaser model "A" UNI 7663.

Use only multifunctional lithium-based oil type NLGI 2.

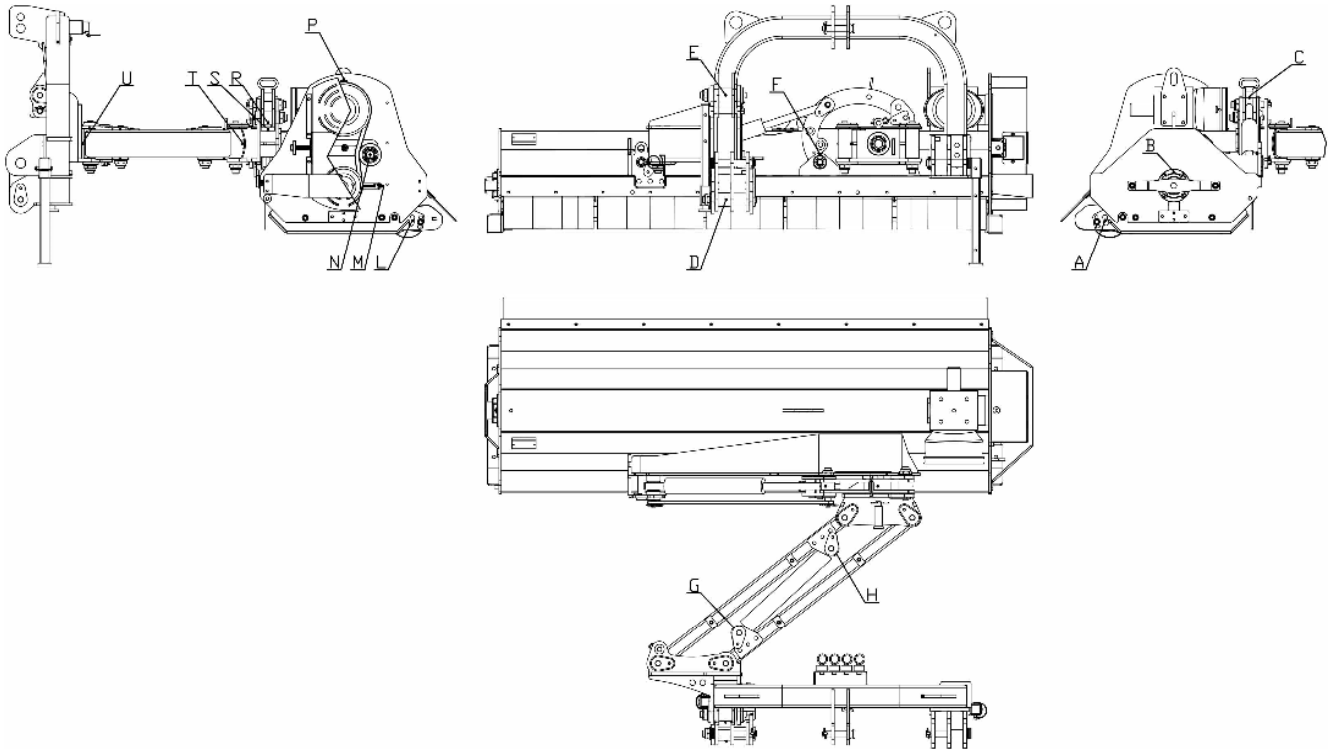

List of greasers:

- "A": right support of the roller n. 1
- "B": right support of the rotor n. 1
- "C": bush of the rotation cylinder stem n. 1
- "D": connecting rod bush n. 1
- "E": bush of the 3-point hitch support n. 1
- "F": bush of the rotation outer connecting rod n. 1
- "G": bush of the side-shift cylinder stem n. 1
- "H": bottom plate bush of the side-shift cylinder n. 1
- "L": left support of the roller n. 1
- "M": left support of the rotor n. 1
- "N": tensioner of the roller n. 1
- "P": left upper support n. 1
- "F": bush of the rotation inner connecting rod n. 1
- "S": rotation connecting rod n. 1
- "T": bush of the side-shift inner connecting rod n. 2
- "U": bush of the side-shift outer connecting rod n. 2

## 2. OIL LEVEL - OIL CHANGE

Check the oil level in the gear box or replace it as indicated in sheet "A".  
To top up the oil, use only SAE 90 OIL.  
Capacity gearbox: 1,5 l.

a) To check the oil level in the gear box, proceed as follows:

1. The machine must be on a flat ground. After removing the plastic protection on the front of the gearbox, unscrew the cap "TL" and check that the oil level is just below the edge of the hole.
2. If the level is OK, tighten the cap "TL" carefully.
3. If the level is low, unscrew the cap of the "TR" and top it up.
4. Once you finished, tighten the caps "TL" and "TR" carefully and put the plastic protection back on.

b) To replace the oil in the gear box, proceed as follows:

1. Remove the protection mounted on the front of the gear box, unscrew the caps "TL", "TR" and the drain cap "TS", then wait until all the oil is out.
2. Screw the drain cap "TS" and add the new oil from cap "TR".
3. Once you finished, tighten the caps "TL" and "TR" carefully and put the plastic protection back.

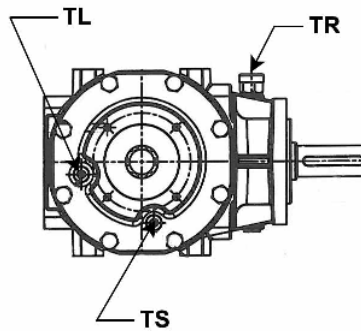



### 3. TOOLS REPLACEMENT

a) To replace the tools, proceed as follows:

1. Unscrew the nut and remove the fixing screw "B".
2. Remove the tools "A" with the corresponding bushes.
3. If the machine is equipped with hammers, there are no bushes.
4. Place the new tool.
5. Insert the screw "B" and tighten the nut.
6. **ATTENTION: all tools must be of the same type.**
7. **ATTENTION: if you change the type of tool, the rotor must be rebalanced.**

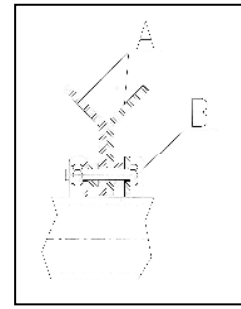

### 4. ADJUSTMENT AND REPLACEMENT OF THE TRANSMISSION BELTS

a) To adjust the tension of the transmission belts, proceed as follows:

1. Remove the cap of the carter "D" unscrewing the 3 screws "A", "B" and "C".
2. Unscrew the locknut "F" and loosen the 2 nuts "E", tighten the screw "G" to stretch the belts or unscrew it to loosen them. The tension is correct when you pull the sides of the belts with your thumb and they give away to a few millimeters.
3. Once the belts are adjusted, tighten the locknut "F", the 2 nuts "E" and mount the carter "D".

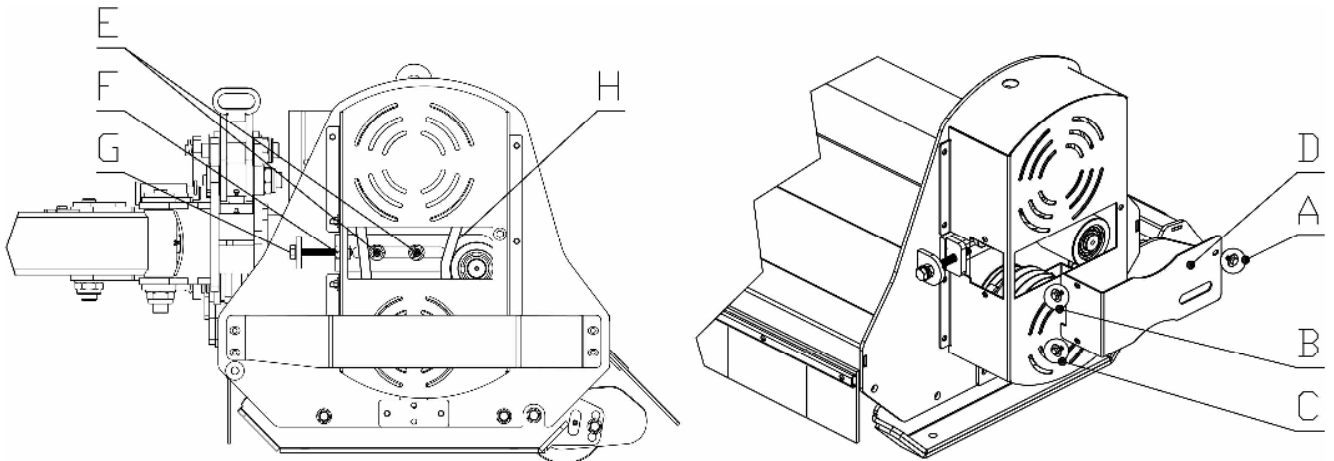

b) To replace the transmission belts, proceed as follows:

1. Remove the protection "A" unscrewing the 4 screws "B".
2. Remove the carter "C" unscrewing the 7 screws "D".
3. Unscrew the locknut "F", loosen the 2 nuts "E" and unscrew completely the adjustment screw "G".
4. Remove the 4 worn out belts "H".  
**Attention:** to avoid tension problems, the belts must be replaced with original belts, whose features are listed in the SPARE PARTS LIST.
5. Mount the 4 new belts.
6. Tighten the screw "G" until reaching optimum tension. The tension is correct when you pull the sides of the belts with your thumb and they give away to a few millimeters.
7. Once the adjustment is completed, screw the locknut "F" and the 2 nuts "E", position the carter "C" and protection "A".

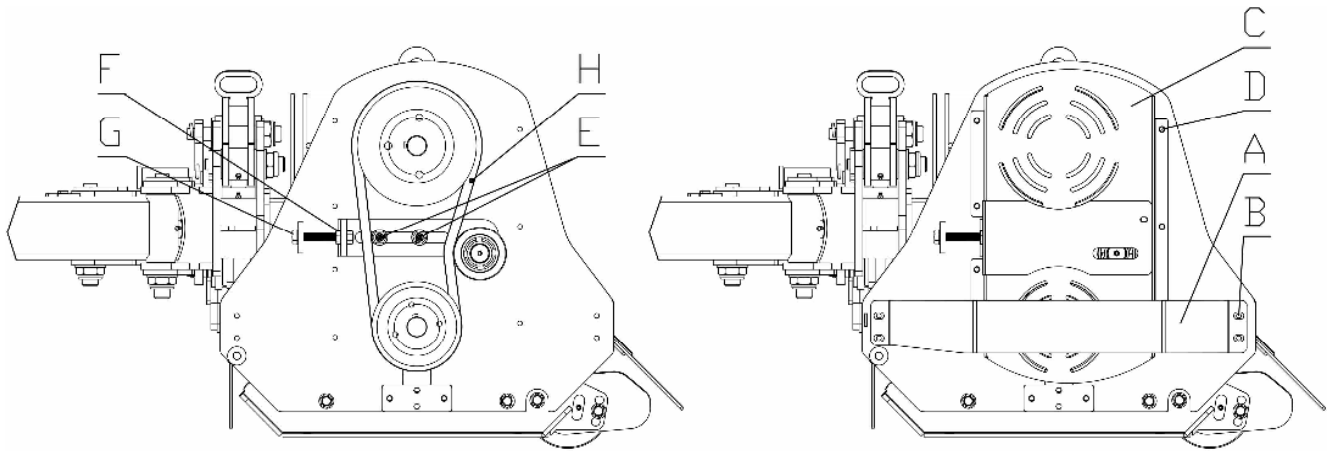

## 5. ASSEMBLING OF THE ADDITIONAL STEEL SKIDS

a) To assemble the additional steel skids proceed as follows:

- 1 Close the additional skid "D" to the slide "E"
- 2 Insert the 2 screws "A" in the holes
- 3 Tighten screw "A" with nut "B" and washer "C"
- 4 Make again the same operation from the other side of the machine.

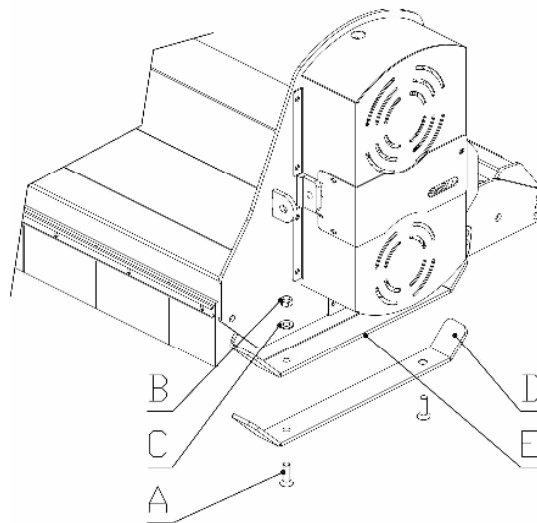

## 6. ASSEMBLING OF THE REAR ROLL EXTENSION

a) To apply the rear roll extension kit :

- 1 Unscrew completely the 2 screws "A" removing nuts and washers
- 2 Make the same operation on the other side of the machine
- 3 Remove the roll "B" with the relating supports
- 4 Assemble the right extension "F" on the right axle of the roll "B" using the screws "A" previously removed
- 5 Make the same operation from the on the other side of the machine
- 6 Slip on the extension, with the roll already assembled, in the 2 skids.
- 7 Insert the 2 screws "E", with the relating washers "C" and "D", in the corresponding holes.
- 8 Tighten the 2 screws "E"
- 9 Make the same operation on the other side of the machine

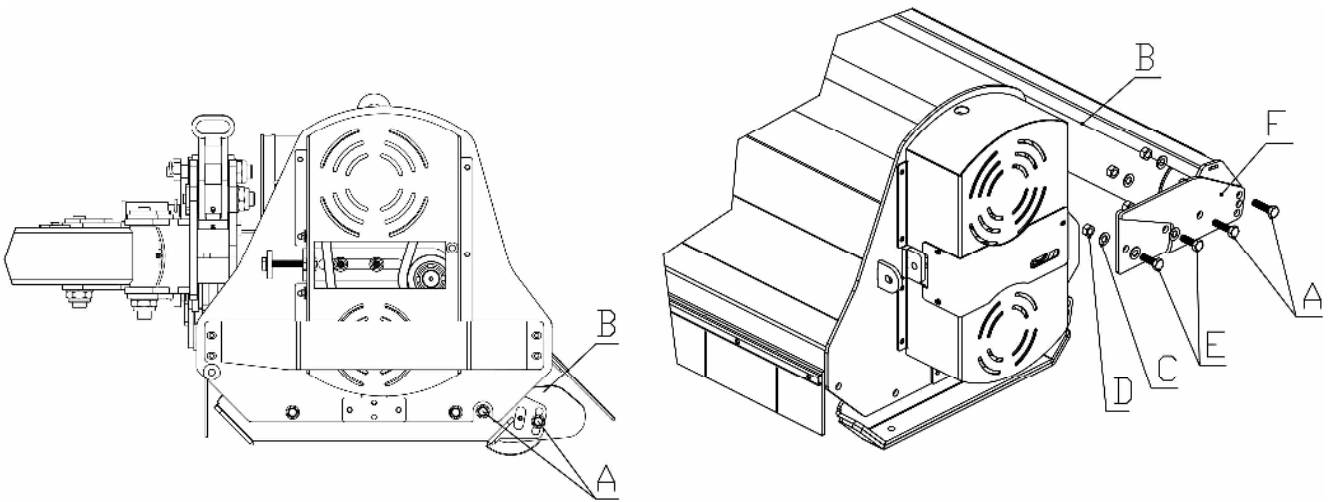

## TROUBLESHOOTING

MALFUNCTIONS	CAUSES AND REMEDIES
<b>Abnormal vibrations</b>	<ul style="list-style-type: none"> <li>- Unbalanced rotor - Contact the dealer.</li> <li>- Loss of one or more tools – Replace them.</li> <li>- Worn out bearings - Replace them.</li> </ul>
<b>Irregular or unsatisfactory cutting</b>	<ul style="list-style-type: none"> <li>- Worn out tools - Replace them.</li> <li>- Non optimal choice of tools - Replace them with another type.</li> </ul>

## TRANSPORTATION

Outside its normal field of use, the machine must be moved with the transmission disconnected.

<**Important**>: Proceed at moderate speed avoiding holes and rough grounds.

<**Note**>: On the road, abide by the traffic laws. On the rear side of the machine, exhibit signs indicating the contour of the machine. Abide by any local regulations.

<**Operations**>: Block the lifter bars of the tractor with chains and parallel tensioners. This prevents the bars from moving side to side.

## DEPOSIT

Store the machine in a dry and not dusty place.

## INFORMATION ABOUT DEMOLITION



At the end of its working life, the machine must be demolished and that can only be done by an authorized authority, in accordance with the national laws about the environment. Therefore, it is necessary to get information from qualified local authorities about the procedure to follow. The machine is mainly composed of iron materials, rubber and epoxide paints.

## WARRANTY

The machine is covered by manufacturer warranty for 24 months.

The warranty is void when:

- a) The machine has not been regularly maintained.
- b) The machine has been used outside its field of use.
- c) The machine has been modified without the prior written permission of the manufacturer.



# **SPARTS AND ACCESSORIES**

SHEETS

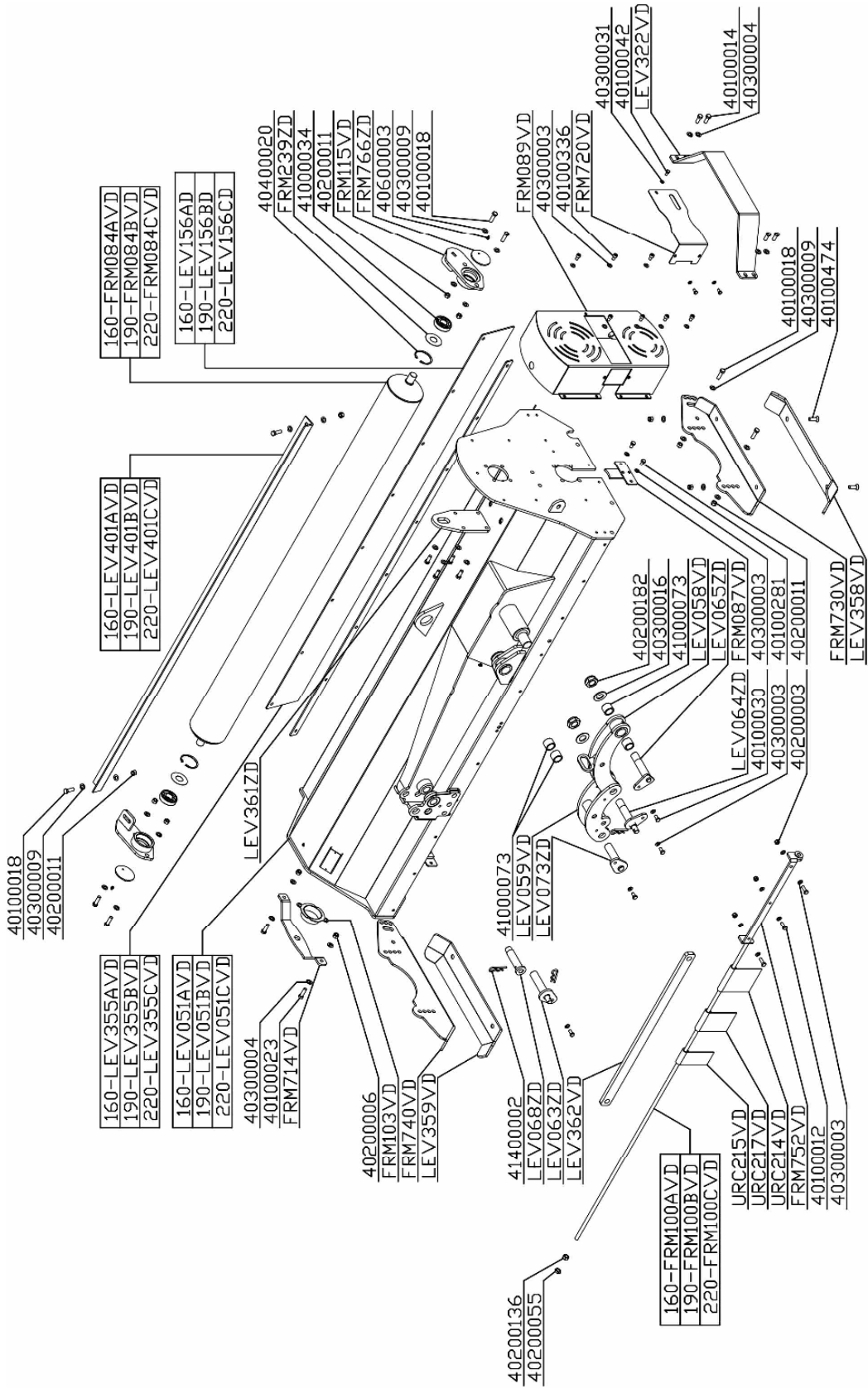

MECHANISMS

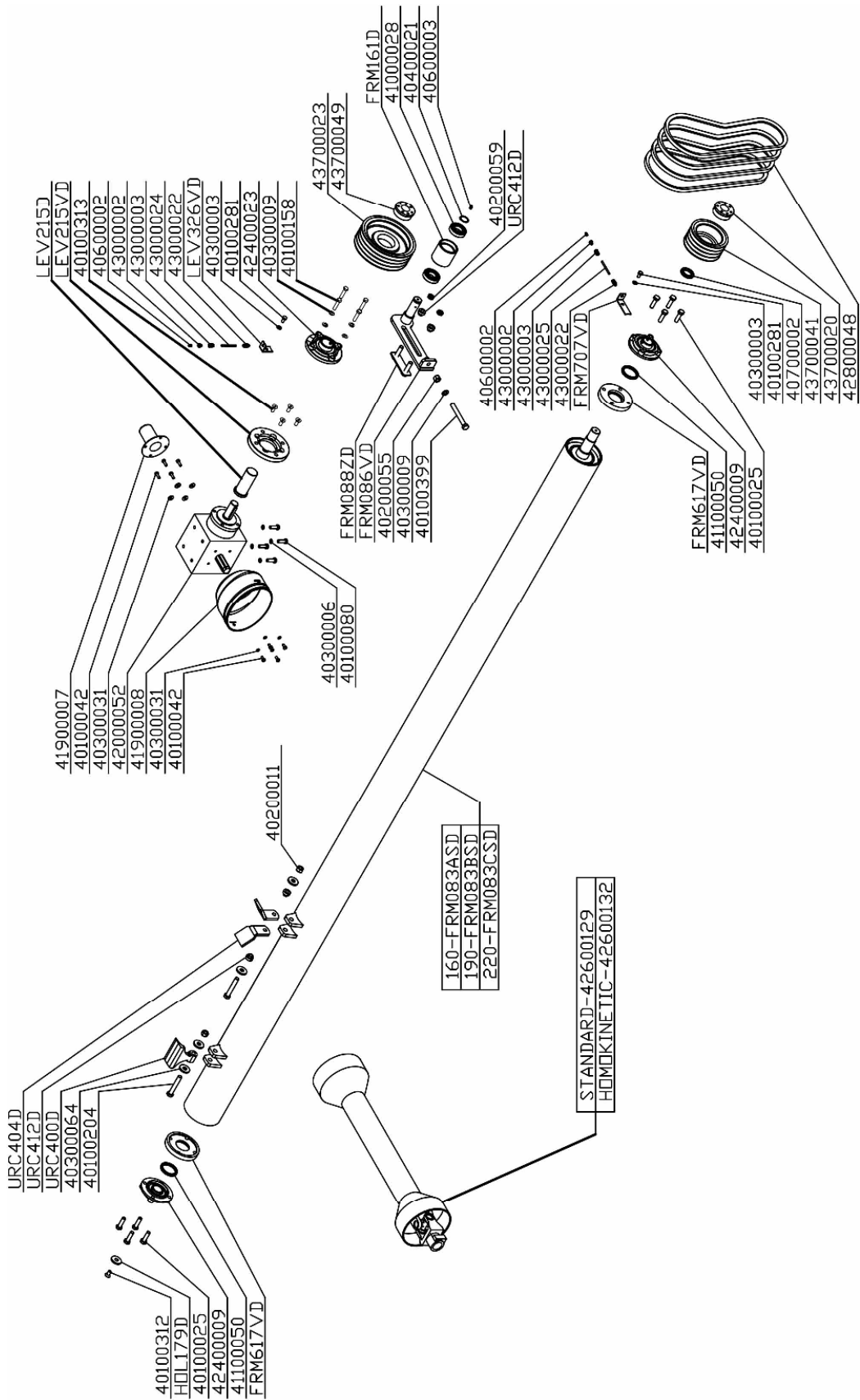



**3-POINT HITCH**

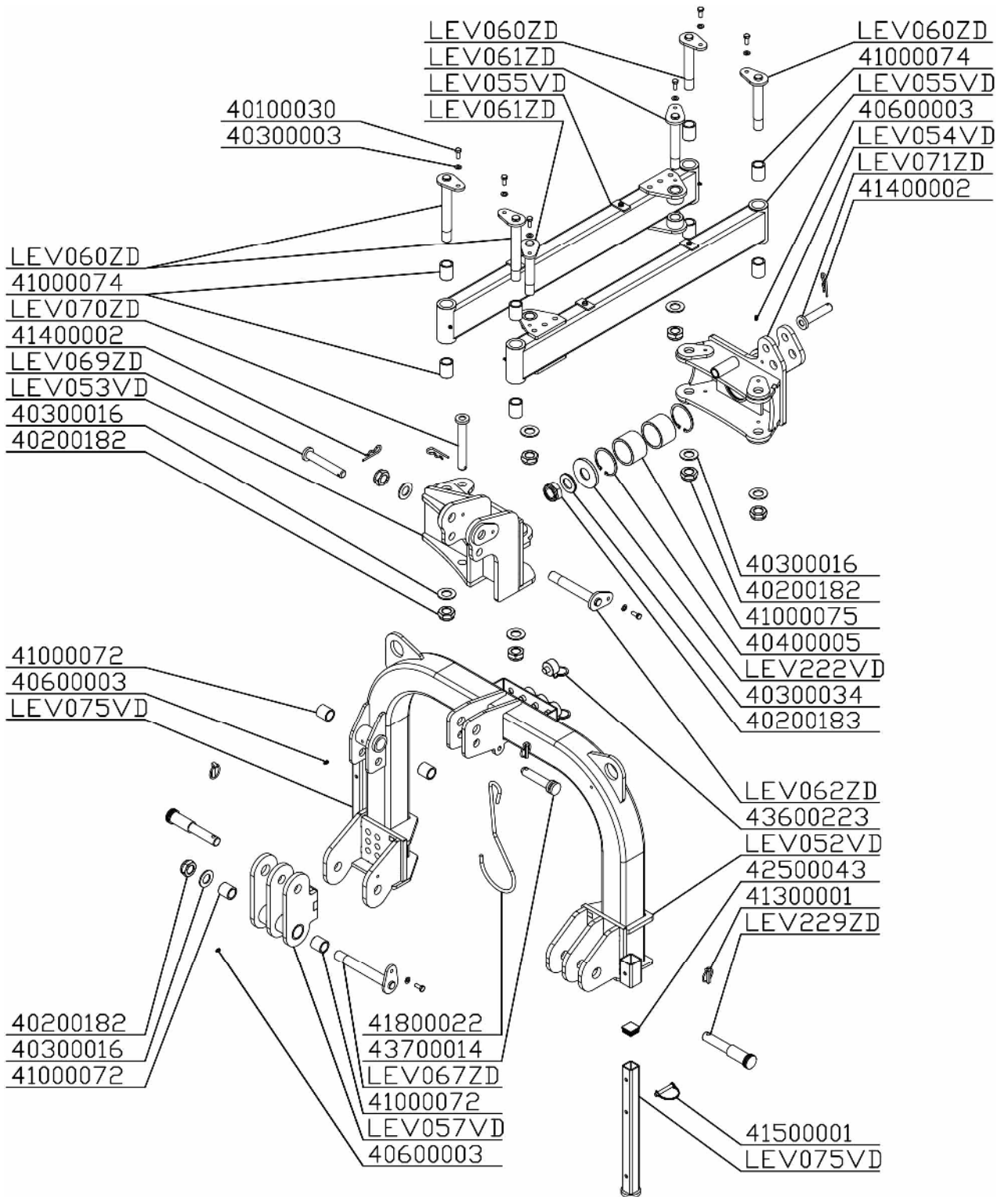

HYDRAULIC SYSTEM

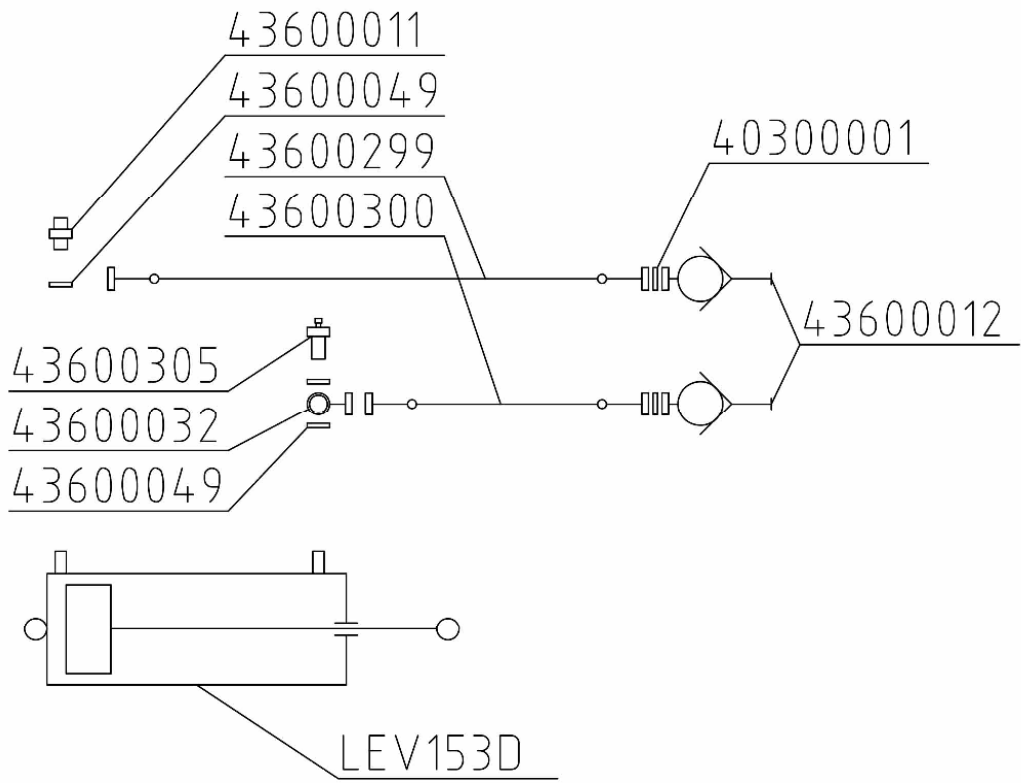

TRASLAZIONE

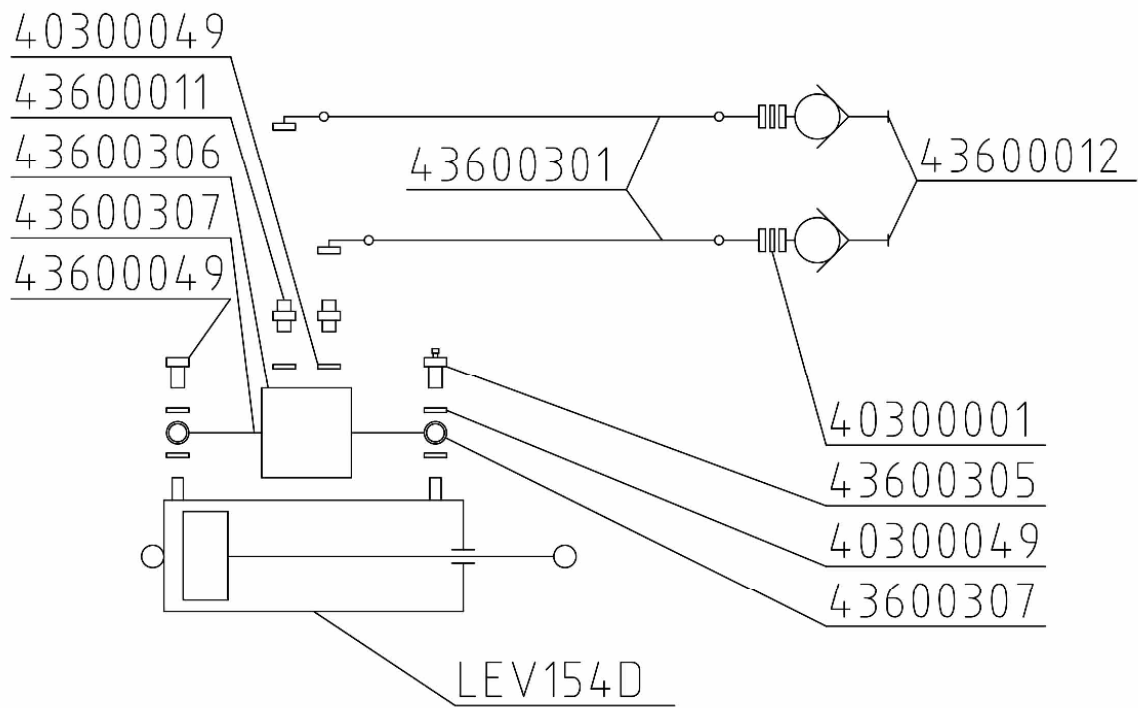

ROTAZIONE

## GENERAL INDEX

<b>PREFACE</b> .....	<b>2</b>
<b>DESCRIPTION</b> .....	<b>3</b>
FIELD OF USE .....	3
PERFORMANCE .....	3
PERFORMANCE LIMITS .....	3
STANDARD EQUIPMENT .....	3
VARIATIONS & OPTIONS .....	3
<b>TECHNICAL FEATURES</b> .....	<b>4</b>
<b>SAFETY INFORMATION</b> .....	<b>5</b>
GENERAL REQUIREMENTS .....	5
RESTRICTIONS OF USE FOR SAFETY .....	5
RUNNING .....	5
<b>SAFETY SIGNALS ON THE MACHINE</b> .....	<b>6</b>
<b>CHECK THE LENGTH OF THE CARDAN SHAFT</b> .....	<b>7</b>
<b>INSTRUCTIONS FOR USE</b> .....	<b>9</b>
FIRST START .....	9
BEFORE STARTING TO WORK .....	10
MOVING AROUND THE WORKING AREA .....	11
START WORKING .....	12
AT THE END OF THE WORK .....	13
<b>MAINTENANCE INSTRUCTIONS</b> .....	<b>14</b>
SHEET "A" SCHEDULED MAINTENANCE .....	14
1. GREASING .....	15
2. OIL LEVEL - OIL CHANGE .....	16
3. TOOLS REPLACEMENT .....	17
4. ADJUSTMENT AND REPLACEMENT OF THE TRANSMISSION BELTS .....	17
5. ASSEMBLING OF THE ADDITIONAL STEEL SKIDS .....	18
6. ASSEMBLING OF THE REAR ROLL EXTENSION .....	19
<b>TROUBLESHOOTING</b> .....	<b>19</b>
<b>TRANSPORTATION</b> .....	<b>20</b>
<b>DEPOSIT</b> .....	<b>20</b>
<b>INFORMATION ABOUT DEMOLITION</b> .....	<b>20</b>
<b>WARRANTY</b> .....	<b>20</b>
<b>WORK AND MAINTENANCE SHEET</b> .....	<b>21</b>
<b>SHEETS</b> .....	<b>23</b>
<b>MECHANISMS</b> .....	<b>24</b>
<b>3-POINT HITCH</b> .....	<b>25</b>
<b>HYDRAULIC SYSTEM</b> .....	<b>26</b>