

Notes



OXDALE PRODUCTS LTD



OPERATING AND MAINTENANCE MANUAL

E300, E400 AND E400D LOG SPLITTER



KEEP FOR FUTURE USE

CONTENTS

Safety	3
Labels	6
Quick Guide Including Transport and Storage	8
In Depth Instructions	11
Warranty Information	18
Technical Specifications	19
Contact Details	20
Declaration of Conformity	21
Electric Motor Instructions	22

Other Information

Manufacturer	Oxdale Products Unit 20 – 21 Foxwood Road Off Sheepbridge Lane Chesterfield S41 9RF		
Year of Construction			
Machinery Type	E300	E400	E400D
Mass of Machine			
Serial Number			
Max. Hydraulic Oil Operating Pressure			

RELATED PRODUCTS

Sawbench

Available as Electric (240v) or PTO.

Electric – Swinging cradle, 600mm blade, cuts logs up to 10” diameter.

PTO – Grizzly 700R has a swinging cradle, suitable for logging, balanced blade for smooth and efficient cutting, 700mm blade which cuts logs up to 12” diameter.



Log Grab

Available in two sizes (42cm and 70 cm log diameter.)

Rear Mounted Crane

Ideal for lifting and moving heavy items behind your tractor and is available with or without lifting chains and timber grab.



Oxdale Products Ltd
Units 20 – 21 Foxwood Road
Off Sheepbridge Lane
Chesterfield
S41 9RF

Tel: 01246 529020

Email: sales@oxdaleproducts.co.uk

Web: www.oxdaleproducts.co.uk



Registered Address:

Oxcroft Stables
30 Oxcroft Estate
Stanfree
Derbyshire
S44 6AU
Company Number: 6490139 England & Wales

SAFETY

OXDALE PRODUCTS REQUIRES THAT ANYONE OPERATING OR MAINTAINING THE LOG SPLITTER SHALL READ AND UNDERSTAND ALL SAFETY, OPERATION AND MAINTENANCE DATA CONTAINED IN THIS USER MANUAL BEFORE USING THE LOG SPLITTER.

The E300, E400 and E400D log splitters are powered by a single-phase electricity supply and should be used in conjunction with a PRCD (Portable Residual Current Device) circuit breaker. They can be used indoors or outdoors, but should be stored in a dry place.

Hydraulic action provides the force to drive a splitting wedge into a log. Never operate the log splitter if unauthorized persons are in the area, especially small children.

Hazards associated with log splitting may be pinch points, splinters, eye injury and entanglement.

IT IS FOR SINGLE PERSON USE ONLY.

YOU ARE RESPONSIBLE FOR THE SAFE OPERATION AND MAINTENANCE OF THE LOG SPLITTER. THE MOST IMPORTANT SAFETY DEVICE ON THE EQUIPMENT IS THE SAFE OPERATOR.

- Keep two hands on the operating levers at all time, never put hands or fingers between the wedge and the log to be split or near moving parts. Always stop the machine before cleaning it or making adjustments.

- The operator should wear suitable PPE including eye protection, gloves and safety boots. Close fitting clothing should be worn to reduce the risk of entanglement.
- Never stand either side of the log splitter whilst operating. Logs can sometimes split apart violently e.g. due to knots. Stand in front of the machine to minimise risk from falling debris.
- Never hold the top of the log whilst setting in place or splitting.
- Never split two logs on top of each other.
- The log splitter is very powerful, but some hard or wet wood can be difficult to split. Do not force the wedge as this could cause injury to yourself and cause damage to the log splitter.
- Never operate the splitter when children or animals are in the danger zones or let children operate the splitter.
- Do not leave machinery unattended whilst it is running.
- Both ends of each log should be cut as square as possible to help prevent the log from riding out of the splitter. This is also aided by the three holes in the log platform having raised edges to reduce the risk of slipping.
- Always choose a working area free from obstructions and then keep the working area free from obstructions such as logs and split wood.
- Machine is for **single person operation only using both hands on the operating lever.**
- Operate splitter on solid ground level.

D=Shaft Diameter
M=PCD Fixing Hole
N=Spigot Diameter
P=Face (Flange) Diameter

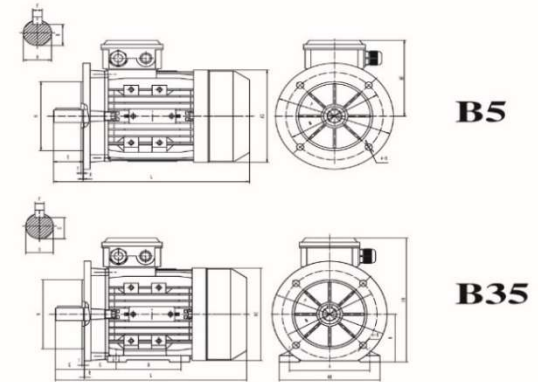

Frame	Installation Size										Installation Size For B5					Overall dimension B35, B5 (Not more than)				
	A	B	C	D	E	F	G	H	K	M	N	P	S	T	AB	AC	AD	L	AD	
56	90	71	36	φ9	20	3	7.2	56	6x9	φ100	φ80	φ120	φ7	3.0	110	φ117	156	196	100	
63	100	80	40	φ11	23	4	8.5	63	7x10	φ115	φ95	φ140	φ10	3.0	120	φ130	171	220	108	
71**	112	90	45	φ14	30	5	11	71	7x10	φ130	φ110	φ160	φ10	3.5	132	φ147	186	241(255)	115	
80	125	100	50	φ19	40	6	15.5	80	10x13	φ165	φ130	φ200	φ12	3.5	160	φ163	213	290	133	
90S	140	100	56	φ24	50	8	20	90	10x13	φ165	φ130	φ200	φ12	3.5	175	φ183	229	312	139	
90L1/L2	140	125	56	φ24	50	8	20	90	10x13	φ165	φ130	φ200	φ12	3.5	175	φ183	229	337/367	139	
100**	160	140	63	φ28	60	8	24	100	12x15	φ215	φ180	φ250	φ15	4.0	198	φ205	252	369(387)	152	
112M	190	140	70	φ28	60	8	24	112	12x15	φ215	φ180	φ250	φ15	4.0	220	φ229	279	395	167	
132S	216	140	89	φ38	80	10	33	132	12x15	φ265	φ230	φ300	φ15	4.0	252	φ265	318	437	186	
132M**	216	178	89	φ38	80	10	33	132	12x15	φ265	φ230	φ300	φ15	4.0	252	φ265	318	475/501	186	
160M/L	254	210/254	108	φ42	110	12	37	160	15x19	φ300	φ250	φ350	φ19	5.0	290	φ325	384	640	224	
180M/L	279	241/279	121	φ48	110	14	42.5	180	15x25	φ300	φ250	φ350	φ19	5.0	340	φ368	440	730	260	
200L	318	305	133	φ55	110	16	49	200	15x29	φ400	φ300	φ350	φ19	5.0	390	φ368	460	745	260	

D=Shaft Diameter
M=PCD Fixing Hole
N=Spigot Diameter
P=Face (Flange) Diameter

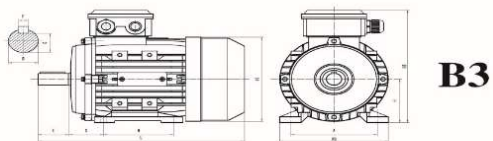

B3

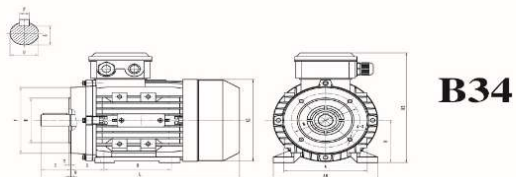

B34

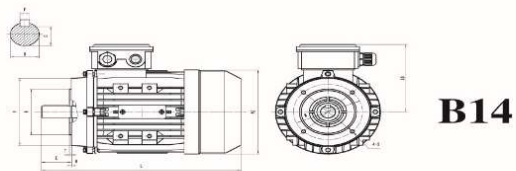

B14

Frame	Installation Size										Installation Size For B14					Overall dimension B3, B14 and B34 (Not more than)				
	A	B	C	D	E	F	G	H	K	M	N	P	S	T	AB	AC	AD	L	AD	
56	90	71	36	φ9	20	3	7.2	56	6x9	φ65	φ50	φ80	M5	2.5	110	φ117	156	196	100	
63	100	80	40	φ11	23	4	8.5	63	7x10	φ75	φ60	φ90	M5	2.5	120	φ130	171	220	108	
71**	112	90	45	φ14	30	5	11	71	7x10	φ85	φ70	φ105	M6	2.5	132	φ147	186	241(255)	115	
80	125	100	50	φ19	40	6	15.5	80	10x13	φ100	φ80	φ120	M6	3.0	160	φ163	213	290	133	
90S	140	100	56	φ24	50	8	20	90	10x13	φ115	φ95	φ140	M8	3.0	175	φ183	229	312	139	
90L1/L2	140	125	56	φ24	50	8	20	90	10x13	φ115	φ95	φ140	M8	3.0	175	φ183	229	337/367	139	
100**	160	140	63	φ28	60	8	24	100	12x15	φ130	φ110	φ160	M8	3.5	198	φ205	252	369(387)	152	
112M	190	140	70	φ28	60	8	24	112	12x15	φ130	φ110	φ160	M8	3.5	220	φ229	279	395	167	
132S	216	140	89	φ38	80	10	33	132	12x15	φ165	φ130	φ200	M10	3.5	252	φ265	318	437	186	
132M**	216	178	89	φ38	80	10	33	132	12x15	φ165	φ130	φ200	M10	3.5	252	φ265	318	475/501	186	
160M/L	254	210/254	108	φ42	110	12	37	160	15x19	φ215	φ180	φ250	M12	4.0	290	φ325	384	640	224	
180M/L	279	241/279	121	φ48	110	14	42.5	180	15x25						340	φ368	440	730	260	
200L	318	305	133	φ55	110	16	49	200	15x29						390	φ368	460	745	260	

- The log splitter is designed only for splitting wood. Using it for any other purpose may damage it and be dangerous to the user and others.
- Ensure that the machine is always stable and secure when in use and is stored safely when not in use in a dry place.

LABELS

The SE400 log splitter should have the following labels attached. If any safety decals are missing or illegible, they should be replaced immediately.

SAFETY LABELS



“Danger! Keep clear of moving parts!”

Always keep hands and any loose clothing out of the way of moving parts, especially the splitting wedge.



“Wear eye protection!”

Splitting logs carries the risk of flying debris, always wear eye protection.



“Wear gloves!”

Log splitting can involve contact with sharp objects, suitable gloves should always be worn.



“Wear appropriate footwear!”

Steel toecap boots should always be worn due to potential for heavy objects to fall off the splitter



“Wear hearing protection!”

Operators are required to wear hearing protection conforming to current standards.

Additionally, on the electric motor unit:

Electrical data and the following safety decal:



“Danger! Electrical supply”

Be aware of electrical supplies to the machine, be aware of worn cables and keep out of standing water

CONNECTION DIAGRAM

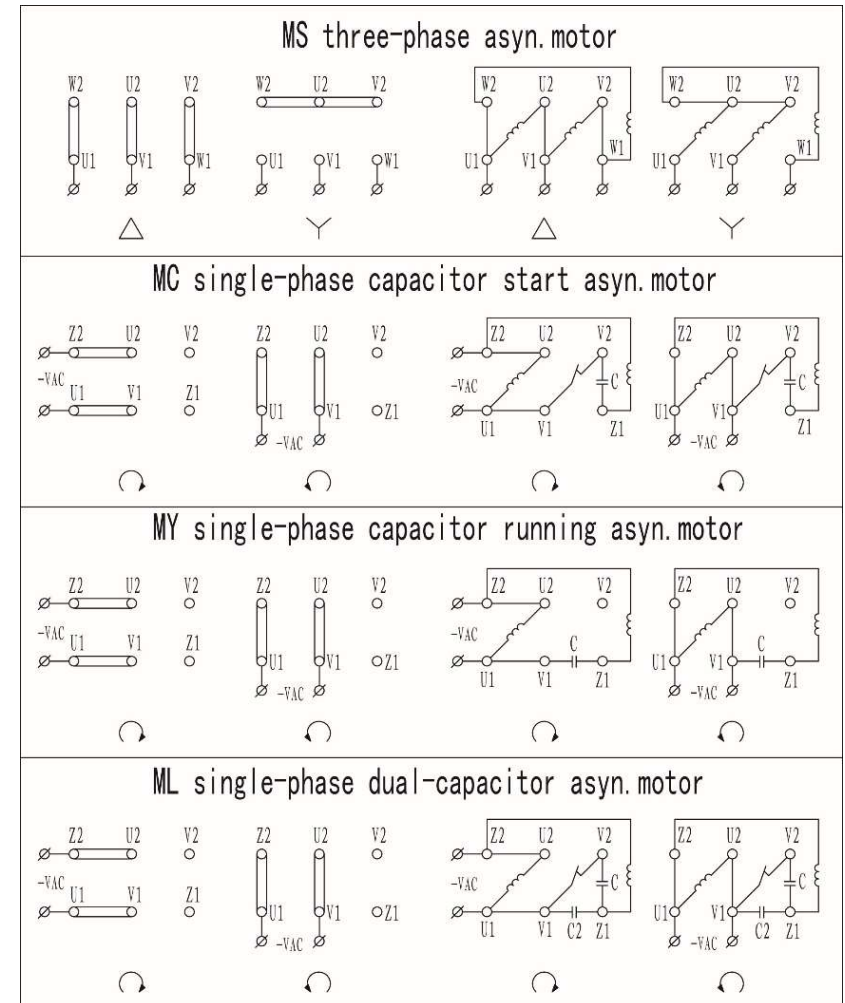

5. To the capacitor starting and resistance starting motors, rear end of the frame mounted with centrifugal switch. On the rear end of the motor base there is furnished a quick-break centrifugal switch.

When the motor is started and attains to a certain speed the switch will give a crisp sound of “click, click” and thus cut off the power supply to the secondary winding with the motor in normal run.

When the motor fails to start or when it does start and attain a certain speed but accompanies with shock and shriek instead of the crisp click, cut off the power supply immediately and carefully inspect the centrifugal switch and the capacitor.

V. Overhaul

In order to insure reliable operation the motor, which should be carried out at regular intervals, usually once a year.

QUICK GUIDE

BEFORE FIRST USE

Before the log splitter can be used for the first time:

- Fill the hydraulic oil tank with 15 litres of hydraulic oil 46 until visual contact on the sight glass can be seen.
- Plug the unit into the mains (single phase, 3 pin, 13-amp socket) in conjunction with a PRCD.
- Start the motor.
- Ram collar to be greased.

OPERATING INSTRUCTIONS

- Position the log splitter on solid level ground when operating.
- Plug the unit into the mains (single phase, 3 pin, 13-amp socket) in conjunction with a PRCD and start the motor.
- Position the log on the operating table so it is lined up with the centre of the wedge
- Secure the log firmly using the log holding device
- Using both hands lift the safety levers to lower the wedge to split the log. The speed can be controlled by how much pressure you put on the control valve.
- Using both hands, lower the operating levers to lift the ram back to the desired height
- Stop splitting if the log starts to move and reposition as per the above instructions.
- Should the wedge lock or become stuck in the log, return the wedge to the fully open position and gently rock the log free before continuing.

POST OPERATING CHECKS AND MAINTENANCE

- Wipe off your log splitter with a damp cloth periodically to keep it free from debris.
- The splitting wedge may need to be sharpened periodically, just using a file.

STORAGE AND TRANSPORTATION

- The electric log splitter should be stored in an upright, vertical position.
- Store in a dry location.
- Store in a safe location where the machine will not get knocked over.
- It should be transported in an upright, vertical position. It should be strapped securely.

7. Wiring

Check the wiring connections before the motor is started. The motor can be started only when the wiring connection is made in accordance with the wiring diagram given on the terminal box. If want to change direction of the motor you may see the wiring diagram to change connection method of the connection strip that may change the direction.

IV. Maintenance of the Motors

1. Daily Cleaning

The motor in use should always be kept clean. No water drops or cotton should be allowed to get into the interior of the motors.

2. Check on Load Current

While the motor is in operation, constant care should be taken to keep the load current below the rated value.

3. Running Sound

During operation of the motor there must be needed no rubbing sound shriek and other random noise, you should stop the motor in time and begin to start it again only after correction has been done.

4. Temperature of the bearings should be below 95 C when the motor is running.

3. Inspection of the Switch

The specification and capacity of the controlling switch should satisfy the requirements indicated on the name plate of the motor. (Such as current capacity size of fuse, etc.)

4. Inspect the Environment

The space surrounding the installation size of the motor should be free from any other corrosive gas. At the same time prevent water drops iron chips and cotton fibres to gain access into the motor. Ample free space should be provided around the motor to facilitate ventilation and heat dissipation.

5. Check Ground Connection

The frame of the motor should be grounded to insure safety.

6. Rotating Condition of the Motor

Before the motor is installed the shaft extension slowly should be turned by hand to make sure that the rotor does not rub or knock against other parts but gives an easy and swift rotation. After the motor has been installed, check the driving belt or the coupler is mounted with good flexibility.

IN DEPTH INSTRUCTIONS

BEFORE FIRST USE

FILLING TANK WITH HYDRAULIC OIL

The hydraulic tank holds approximately 14 litres of hydraulic oil, we would recommend using ISO46 type oil.

The tank is filled through the filler cap on top of the unit. Pour the oil in until you have filled the tank as indicated on the level gauge. Please note that once the unit has been run for the first time and the pump filter and pipe work filled you will need to top up the tank.



Level Gauge



Filler Cap

RUNNING FOR THE FIRST TIME

Plug the unit into the mains, (single phase, 3 pin,13-amp socket) using an PRCD to help protect the user. Press the black button to start the motor and the red one to stop the motor.



GREASING

The ram collar needs to be greased where it slides down the guide; this will help reduce the friction and help the unit run more smoothly. This needs to be carried out every 10 hours or alternatively at the start of each day.

Ram Collar

2. Storage

The motors should be stored in a dry and well-ventilated indoor storage. Should not be stored in a storage which is full of corrosive gas.

III. Preliminaries Before Operation

1. Check the Insulation Resistance

Before the motor is put into operation the insulation resistance between its winding and that of the windings respect to ground with a megaohm meter of 500V. The rate of the resistance is more than 1.0 megaohm, otherwise, the winding should be treated with heat-baking.

If it is available a voltage in the range of 1/3 to 1/2 of the rated value can be applied to get the motor running at no load one hour or so, until the dampness is expelled.

2. Check the line Voltage

Connect the line voltage in accordance with the value indicated on the nameplate of the motors. To the double voltage motor should be more care the motor voltage and power voltage just the same on the connection plate

I. Name of Model

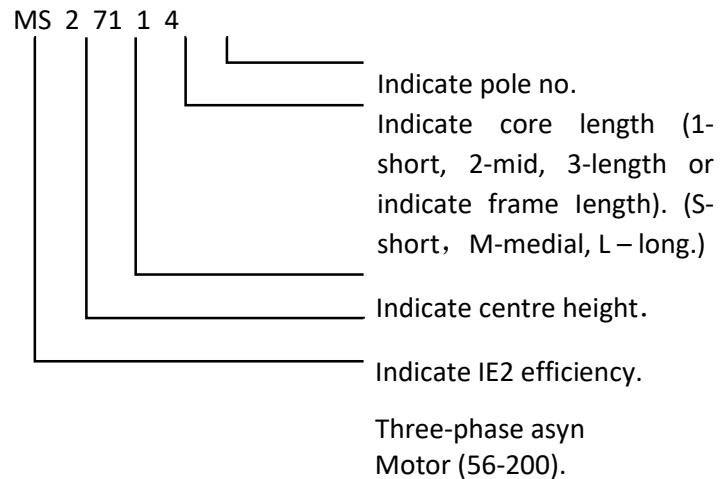

MC--Single-phase capacitor start asyn.motor(63-112)
MY--Single-phase capacitor running asyn.motor(56-100)
ML--Single-phase dual value capacitor motor (63-112)

II. Transportation and Storage of the Motors

1. Transportation

During transportation, care must be taken to keep the motor in upright position and place it flat, without being inverted or laterally laid. When being craned, it should be lifted or lowered slowly, but not jerkily. At the same time, it should be kept the rain and dew away from invasion into the machine and making it damp.

Operating Instructions

These instructions are designed for the safety of the operator and the machine

The log splitter is designed for splitting logs only AND IS FOR SINGLE PERSON USE. It can handle logs no bigger than 450mm and having a diameter no bigger than 900mm and no smaller than 75mm in diameter.

Only persons who are competent to do so and having read this manual, in full, should use the log splitter.

Before using the log splitter for the first time each day a visual inspection should be carried out as explained in the operators guide.

When operating the unit, it should be positioned on solid and as far as possible, level ground. Wheel blocks should be used to prevent movement of the machine. Both hands should be kept on the leavers when the ram is being extended and retracted. Lifting the handle will extend the ram and lowering the handle will retract the ram.

Log holding device

Pick the log to be split. This should have been cut square at both ends. This is very important as it will reduce the chance that the log will slip.

Position the log under the point of the wedge, unhook the chain on the log holding device and pass round the log before hooking back in place

Place both hands on the safety handles and operating leavers and lift to lower the wedge into the log.

Stop lowering the wedge if the log starts to go sideways and reposition. If the wedge gets stuck, return the wedge to the fully open position and rock the log free before continuing.

Use both hands to push the operating leavers down and return the wedge back to the desired height.

When splitting wood always stand in front of the unit and not to the side as logs can split with some force and be thrown off the unit to the sides. Always keep other people and pets/animals out of the area when splitting logs.

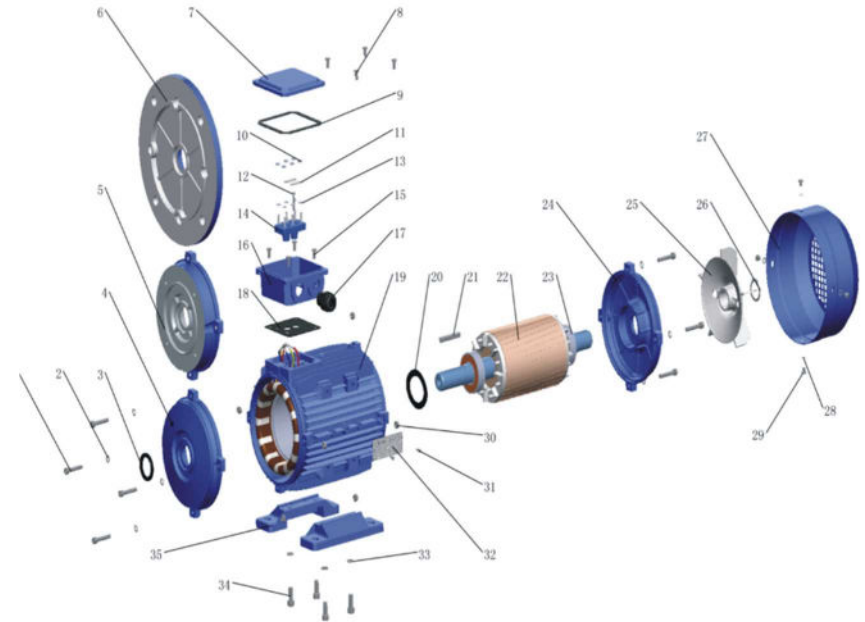

- | | |
|------------------------------|---------------------------|
| 1.Screw | 19.Frame |
| 2.Gasket | 20.Preload washer |
| 3.Oil seal | 21.Key |
| 4.Front endshield | 22.Rotor |
| 5.B14 flange | 23.Bearing |
| 6.B5 flange | 24.NDE endshield |
| 7.TB cover | 25.Cooling fan |
| 8.TB fixing screws | 26.Fan circlip |
| 9.TB upper gasket | 27.Fan cover |
| 10.Terminal board fixing nut | 28.Fan cover fixing shim |
| 11.Terminal bridge | 29.Fan cover fixig screws |
| 12.Terminal pin | 30.Endshield fixing nut |
| 13.Terminal shim | 31.Rivet |
| 14.Terminal board | 32.Nameplate |
| 15.TB fixing screws | 33.Foot fixing nut |
| 16.TB base | 34.Foot fixing screws |
| 17.Cable gland | 35.Foot |
| 18.TB bottom gasket | |

MS、MC、MY、ML、MS2 Series

ASYN. MOTORS INSTRUCTION FOR OPERATION AND MAINTENANCE



With both hands, clasp both levers and push up to lower the wedge



Using both hands, pull the leavers down to lift the wedge

Let go of the leavers or return them to the neutral position to stop the wedge

If the wedge gets stuck, return the wedge to the fully open position and rock the log free before continuing. When splitting wood always stand in front of the unit and not to the side as logs can split with some force and be thrown off the unit to the sides.

Always keep other people and pets/animals out of this area when splitting logs.

POST OPERATION AND MAINTENANCE INSTRUCTIONS

At the end of each day's work the unit should be cleaned. The removal of wood chips etc from the unit is advisable as well as removing contaminated grease for the wedge collar. Sharpen the wedge as and when required, this can be done with a file. Check for any loose bolts or other damage at regular intervals. If the log splitter is going to be stored then this should be upright in a dry location.

Hydraulic System

Periodically check the hydraulic oil level with the gauge on the side of the unit and top if required.

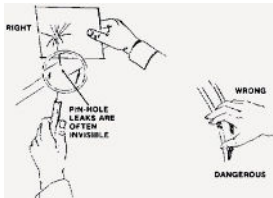

Check for oil leaks, worn hoses and loose fittings. The pressure in the hydraulic system can exceed 2000 PSI. Reinforced hoses can develop pin hole leaks and hydraulic connections can vibrate loose. Hydraulic leaks may be

hard to see. **Never check for leaks with your hand as the high pressure can inject oil under the skin. This is a medical emergency and if this happens immediate medical attention must be sought.**

Place your hand near the connection to sense for heat before touching the connection. If hot, allow the hydraulic system to cool down before touching the heated connections.

B5

DECLARATION OF CONFORMITY FOR CE MARKING

Company contact details:

Oxdale Products LTD (formerly CS Trading),

Units 20-21, Foxwood Rd, Chesterfield, Derbyshire, S41 9RF, UK

Registered Address:

Units 20-21, Foxwood Rd, Chesterfield, Derbyshire, S41 9RF, UK

Telephone:

01246 529020

Technical file compiled by:

Brian Thurman, Cobweb Cottage, 43 Main Road, Higham, Derbyshire, DE55 6EH, UK

Oxdale Products LTD declares that the product:

Oxdale E300/E400/E400D log splitters

Conforms with the following EU Directives:

Directive 2006/42/EC Machinery

And conforms with the following EU Harmonized Standards:

EN 609-1:1999

Name of signatory:

Chris Butcher

Position of signatory:

Director

Signed:

C. Butcher

Dated:

20/1/13

Place:

Stanfree

CONTACT DETAILS

Oxdale Products can be contacted using the details below, these details can also be used for ordering spare parts.

Oxdale Products Ltd
Units 20 – 21 Foxwood Road
Off Sheepbridge Lane
Chesterfield
S41 9RF

Tel: 01246 529020

Email: sales@oxdaleproducts.co.uk

Web: www.oxdaleproducts.co.uk

FILTER ELEMENT REPLACEMENT: remove the top cover on the filter body and using the handle on top of the filter remove from the filter body. Replacement is a reversal of removal.

Looking after the hydraulic oil is very important, keeping the oil free from contamination will reduce the need to change the oil. If you need to change the oil you can drain the oil through the feed pipe to the pump. Remove the pipe from the pump and drain into a suitable container, if you are replacing the oil then replacement of the filter element is also required. Replace the pipe and filter before refilling the tank. Check the oil level once it has been run and top up as required.

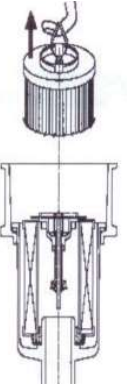

Electric Motor

The electric motor unit should only be opened by a qualified electrician. Oxdale Products Ltd recommends annual servicing and PAT testing by a qualified electrician. The instructions for the motor unit from the suppliers, is included in this user manual.

WARRANTY

Warranty claims which arise as a result of incorrect operation, insufficient maintenance or the use of non-approved consumables, e.g. lubricants, hydraulic oils will not be accepted by the manufacturer.

Only original Oxdale parts may be used. When ordering replacement parts, please provide the model name and number.

Pressure adjustments to the valves must only be carried out by Oxdale authorised dealers.

No liability is accepted for damage caused by Oxdale products in so far as they are caused by incorrect repairs or the non-use of original Oxdale replacement parts or in so far as repairs have not been carried out by Oxdale or a pre-authorized specialist, the same applies to auxiliary parts and accessories.

All warranty claims are on a return to manufacturer basis.

All Oxdale products have a full 12 months warranty.

TECHNICAL SPECIFICATIONS E300, E400 AND E400D

LOG		LOG SPLITTER	MODEL NO.
Weight	60kg	Max Pressure	4780psi/330
		Ram Bore	60mm
Noise	<70db(A)	Ram Stroke	300mm and
		Ram Rod	40mm
MOT	Kramp	Pump	Saturn Group 2
KW	1.5	Input Speed	1450 rpm
V	230	Torque	33n/m
A	8.8	Displacement	3.2 cc/rev
IP	55	Flow	4.3 l/min
		Max	250 bar / 3625
		Max Peak	290 bar / 4200
Filter	MP Filtri MPF0301A	Spool Block	MB2
Type	Return	Max	250 bar/3600
Filter	0301P25N	Max Peak	320 bar/4600
		Max Back	30 bar/430 psi
		Port Marked	Pressure Line
		Port Marked	Exhaust Line
		Relief Valve	270 bar/3900